

RIEV/TECH

Advanced Control • Simple Maintenance • Reliable • Economical



MICRO PLC PR SERIES

***Programmable* Logic Controller**

Introducing

What is a Logic Controller?

A Logic Controller is a compact electronic device included in the Micro-PLC family. It can be used to control and monitor a set of conditions according to the state of the sensors, the passing of time and the program created using software. Logic Controllers can be preprogrammed to perform certain tasks (time, count, detect, display, communicate or process) and at specific and selected times and intervals. Logic Controllers use either relays or solid state outputs to control operations.

Forget individual components, such as rotary timers, cube relays, counters and contactors – or complex and expensive PLCs. Logic Controllers can meet your control needs in a variety of compact, stand-alone and low-complexity applications.

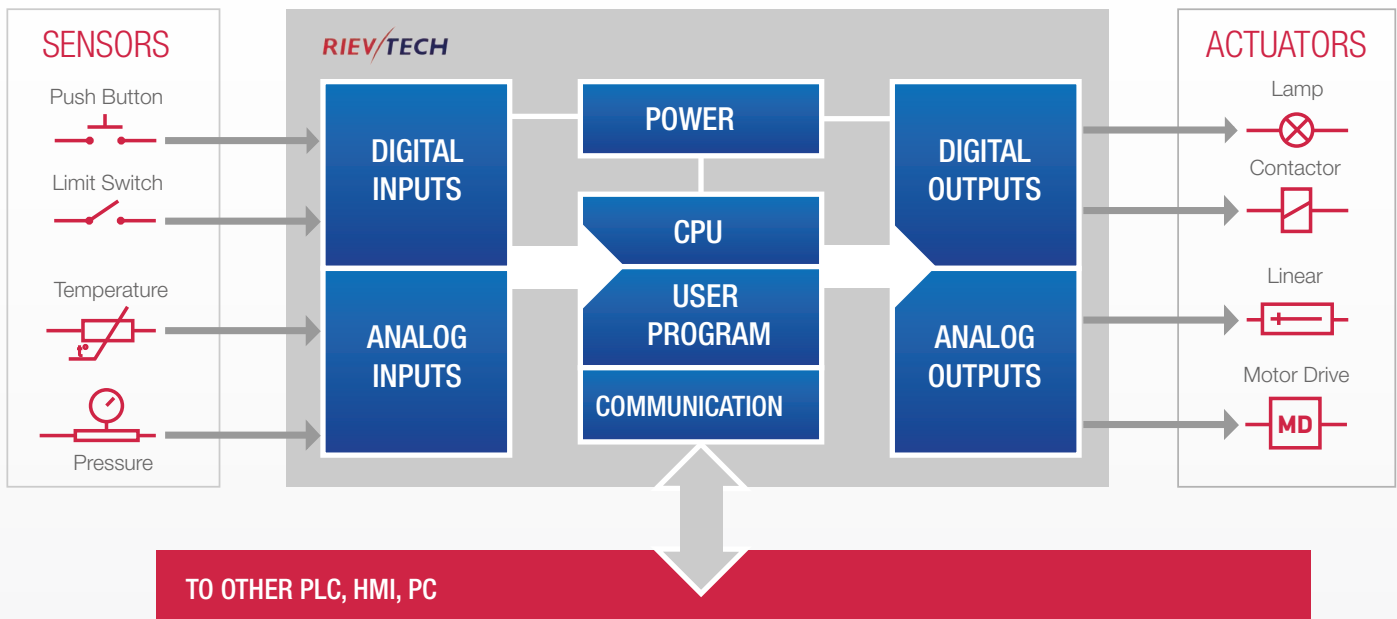

Rievtech Micro PLC Series

Rievtech Micro PLC is a highly reliable, easy-to-use and wide-range product. It will become an indispensable assistant for those who want to optimize and automate their production or system. Rievtech Micro PLC is versatile! They are a high quality product! As the manufacturer, we provide excellent technical support and help! Choosing our brand of Micro PLC will provide you with confidence in your choice!

In addition to the features and interfaces common to most PLCs, Rievtech Micro PLCs incorporate a number of advanced features. Some of these features include high speed outputs (as example

for stepper motion control), PWM (pulse width modulation), PID control, high speed pulse counter inputs, LCD and keypad, support Modbus protocols (Master mode as well) and other.

Models have additional communications ports for interfacing HMIs, other PLCs and other devices.

Rievtech Micro PLCs are programmable, using Rievtech's xLogic software.

Benefits



Enhanced and efficient development process



Reduced system cost



Reduced development time



Improved reliability



Rapid development and deployment

Main Applications

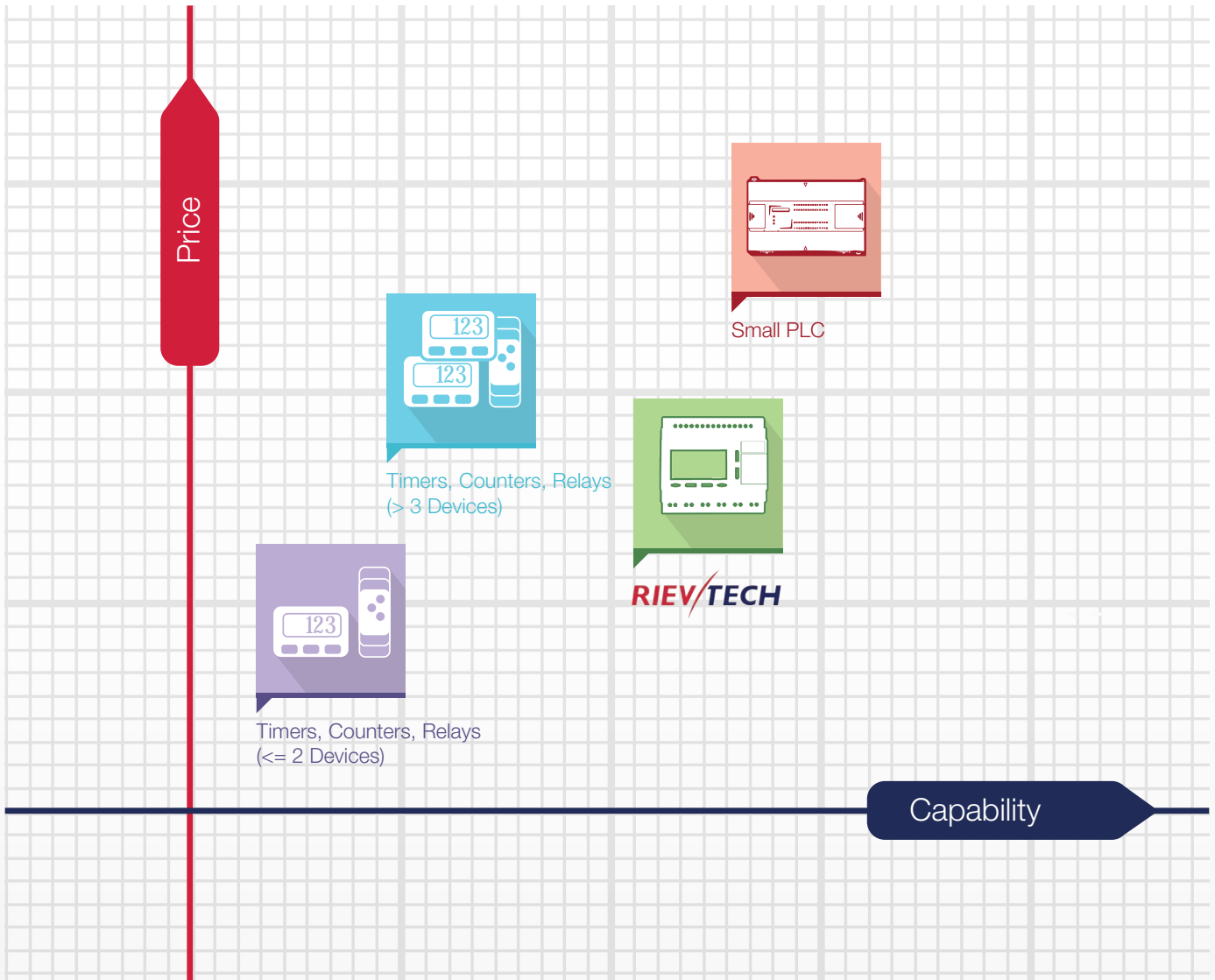

Building Automation

Smart Home, Data Center, Hotels, Hypermarket, Offices, Residential, Shopping centers, Greenhouses, Warehouses, Breeding complexes



Process Automation

Agricultural and Food Industry, Printing and paper industry, Material Handling Industries, Textile industry, Water & Wastewater Treatment, Forming Technology/Sheet Metal Working



Machine Automation

Vending machines, Woodworking Machines, Plastic Machines, Machine Tools, Window Production Machines, Washing Machines, Test facilities



Smart Energy

Wind Turbine, Solar energy, Heat pumps, Heaters, Power generators

Product Line-UP

PR-6 Series

PR-12 Series

6 I/O Not Expandable

12 I/O Not Expandable

- PR-6AC-R **AC**
- PR-6DC-DA-R **DC**
- PR-12AC-R-E **AC**
- PR-12DC-DA-R-E **DC**
- PR-12AC-R **AC**
- PR-12DC-DA-R **DC**
- PR-12DC-DA-TN **DC**



Model	PR-6AC-R	PR-6DC-DA-R	PR-12AC-R-E	PR-12DC-DA-R-E	PR-12AC-R	PR-12DC-DA-R	PR-12DC-DA-TN
Power	110-240V AC	12-24V DC	110-240V AC	12-24V DC	110-240V AC	12-24V DC	12-24V DC
Inputs	4	4	8	8	8	8	8
As Analog	No	4 (0-10V) 9 Bit	No	4 (0-10V) 9 Bit	No	4 (0-10V) 10 Bit	4 (0-10V) 10 Bit
Outputs	2 Relay	2 Relay	4 Relay	4 Relay	4 Relay	4 Relay	4 Transistor PNP
LCD	No	No	No	No	LCD 4x16 Symbols	LCD 4x16 Symbols	LCD 4x16 Symbols
Expansion	No	No	No	No	No	No	No
Real Time Clock	RTC with Backup	RTC with Backup	RTC with Backup	RTC with Backup	RTC with Backup	RTC with Backup	RTC with Backup
Program Memory	64 Blocks	64 Blocks	64 Blocks	64 Blocks	512 Blocks/5k Steps	512 Blocks/5k Steps	512 Blocks/5k Steps
High-speed Inputs	No	No	No	No	No	4 Channels 60kHz	4 Channels 60kHz
High-speed outputs	No	No	No	No	No	No	2 Channels 10kHz
COM Ports1	RS232 with Cable (RS232) RS485 with Cable (P10-RS485)	RS232 with Cable (RS232) RS485 with Cable (P10-RS485)	RS232 with Cable (RS232) RS485 with Cable (P10-RS485)	RS232 with Cable (RS232) RS485 with Cable (P10-RS485)	RS232 with Cable (RS232) RS485 with Cable (P10-RS485)	RS232 with Cable (RS232) RS485 with Cable (P10-RS485)	RS232 with Cable (RS232) RS485 with Cable (P10-RS485)
Size	2DIN	2DIN	4DIN	4DIN	4DIN	4DIN	4DIN

1 - Only one type of a Cable can be connected to Universal Port

PR-14 Series

PR-18 Series

PR-24 Series

14 I/O Expandable

18 I/O Expandable

24 I/O Expandable

- PR-14AC-R **AC**
- PR-14DC-DA-R **DC**
- PR-18AC-R **AC**
- PR-18DC-DA-R **DC**
- PR-18DC-DA-RT **DC**
- PR-24AC-R **AC**
- PR-24DC-DA-R **DC**
- PR-24DC-DAI-RTA **DC**



Model	PR-14AC-R	PR-14DC-DA-R	PR-18AC-R	PR-18DC-DA-R	PR-18DC-DA-RT	PR-24AC-R	PR-24DC-DA-R	PR-24DC-DAI-RTA
Power	110-240V AC	12-24V DC	110-240V AC	12-24V DC	12-24V DC	110-240V AC	12-24V DC	12-24V DC
Inputs	10	10	12	12	12	14	14	14 (12 Digital)
As Analog	No	6 (0-10V) 10 Bit	No	6 (0-10V) 10 Bit	6 (0-10V) 10 Bit	No	6 (0-10V) 10 Bit	6 (0-10V) 10 Bit 2 (0-20mA) 10 Bit
Outputs	4 Relay	4 Relay	6 Relay	6 Relay	4 Relay 4 Trans. PNP	10 Relay	10 Relay	6 Relay 2 Trans. PNP 1 Analog
LCD	LCD 4x16 Symbols	LCD 4x16 Symbols	LCD 4x16 Symbols	LCD 4x16 Symbols	LCD 4x16 Symbols	LCD 4x16 Symbols	LCD 4x16 Symbols	LCD 4x16 Symbols
Expansion	Up to 16 Modules	Up to 16 Modules	Up to 16 Modules	Up to 16 Modules	Up to 16 Modules	Up to 16 Modules	Up to 16 Modules	Up to 16 Modules
Real Time Clock	RTC with Backup	RTC with Backup	RTC with Backup	RTC with Backup	RTC with Backup	RTC with Backup	RTC with Backup	RTC with Backup
Program Memory	512 Blocks/5k Steps	512 Blocks/5k Steps	1024 Blocks/13k Steps	1024 Blocks/13k Steps	1024 Blocks/13k Steps	1024 Blocks/13k Steps	1024 Blocks/13k Steps	1024 Blocks/13k Steps
High-speed Inputs	No	4 Channels 60kHz	No	4 Channels 60kHz	4 Channels 60kHz	No	4 Channels 60kHz	4 Channels 60kHz
High-speed outputs	No	No	No	No	2 Channels 10kHz	No	No	2 Channels 10kHz
COM Ports1	RS232 with Cable (RS232) RS485 with Cable (P10-RS485) RS485 Built-in RS485 with Module (P10-RS485)	RS232 with Cable (RS232) RS485 with Cable (P10-RS485) RS485 Built-in RS485 with Module (P10-RS485)	RS232 with Cable (RS232) RS485 with Cable (P10-RS485) RS485 with Module (P10-RS485)	RS232 with Cable (RS232) RS485 with Cable (P10-RS485) RS485 with Module (P10-RS485)	RS232 with Cable (RS232) RS485 with Cable (P10-RS485) RS485 with Module (P10-RS485)	RS232 with Cable (RS232) RS485 with Cable (P10-RS485) RS485 Built-in RS485 with Module (P10-RS485)	RS232 with Cable (RS232) RS485 with Cable (P10-RS485) RS485 Built-in RS485 with Module (P10-RS485)	RS232 with Cable (RS232) RS485 with Cable (P10-RS485) RS485 Built-in RS485 with Module (P10-RS485)
Size	6DIN	6DIN	6DIN	6DIN	6DIN	8DIN	8DIN	8DIN

Please refer to specification pages for the details of each model

1 - Only one type of a Cable can be connected to Universal Port

Digital Inputs

All Rievtech PLCs accept a some number of digital inputs. Digital inputs sense binary status, such as on/off, switch open/closed, etc.

The AC versions of the Micro PLC are suitable for operation with rated voltages between 110 V AC and 240 V AC. The DC versions can be operated with a 12 - 24 V DC power supply.

Any connection to AC voltage more than 79 V AC is sensed as a '1' (for AC versions) or DC voltage more than 10 V DC (for DC versions). Voltage below 40V AC (or 5V DC for DC versions) or an open connection is sensed as '0'.

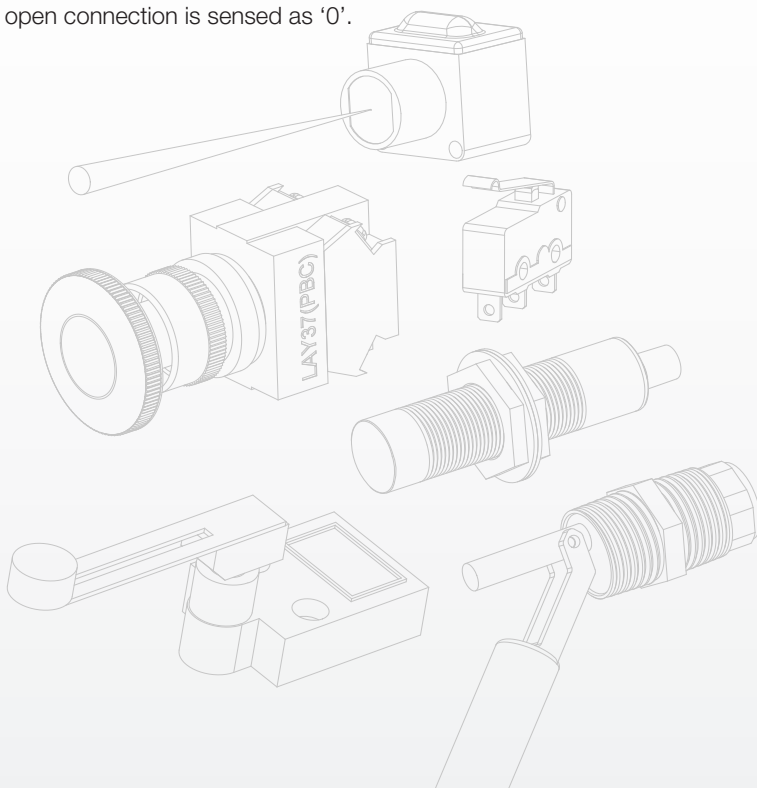

Digital Input Sensors



- Push buttons
- Limit switches
- Proximity sensors
- Photo-electric sensors
- Level switches
- Pressure switches
- Auxiliary contacts of a contactors
- Relay/contactor contacts

The minimum time for a change in state of a digital input, is 50ms for the change to be detected (except high speed inputs which can operate up to 60 kHz).

Digital inputs include push-buttons, limit switches, relay contacts, proximity switches, photo sensors (On/Off), pressure switches and more. Digital input devices are available in both DC as well as AC and some are voltage independent such as a switch contact.

AC Input

Sinking DC Input

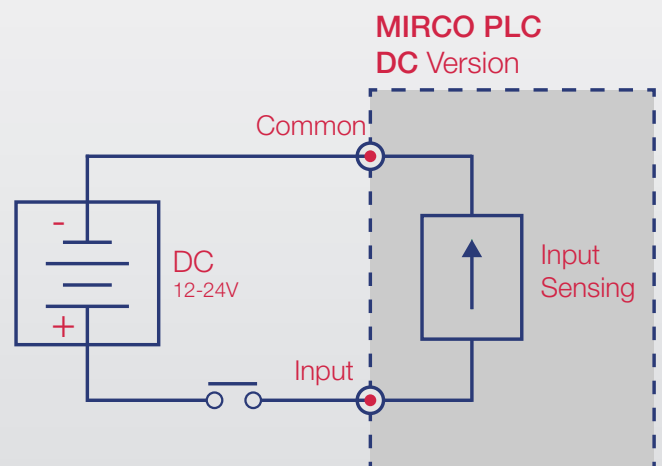
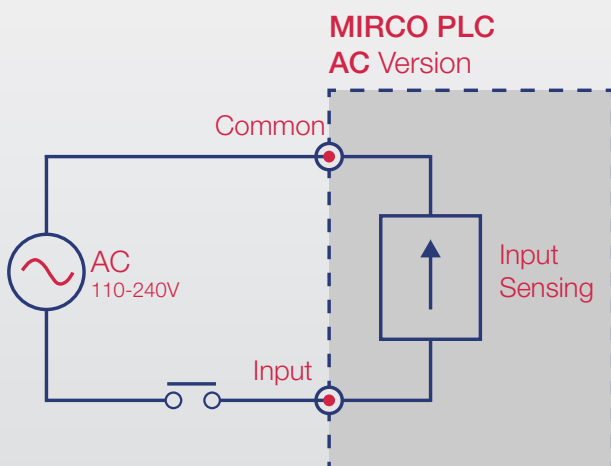

Inputs

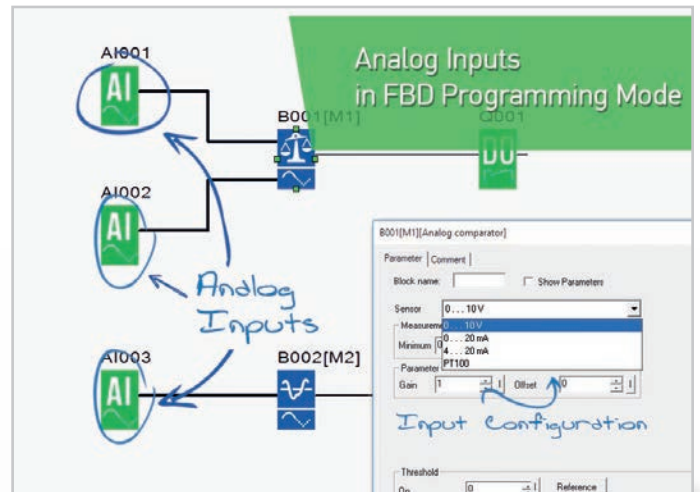
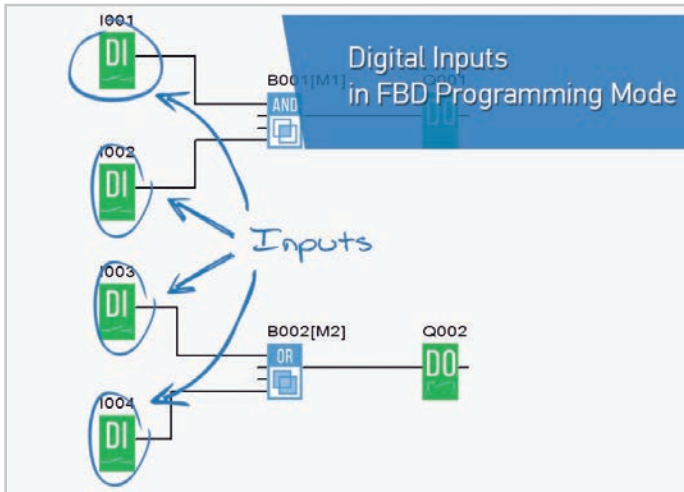

Analog Inputs

Rievtech Micro PLCs are available with analog inputs too. PLC analog input interfaces are available for either 0-10VDC, 0-20mA or PT100.

Analog inputs are normally used to connect to transducer outputs. Such transducers measure some physical parameter, such as pressure, temperature, liquid level, position, pH level, or other such continuously variable measurement. The transducer signal output should be connected to a signal input on the PLC analog input channel and the transducer return or ground reference line must be connected to the PLC common.

Some CPUs can be set to either analog or digital for use in the program. They will be recognized as analog inputs when the input terminal is connected with an analog function block, and they will be recognized as switching inputs when the input terminal is not connected with an analog function block.

Full range analog signals will convert to a value between 0 and 1000 (10 bits) for inputs on CPU and to a value between 0 and 512 (9 bit) for expansion modules.

Scale function in xLogicSoft can be used to automatically convert the signal value to meaningful data.

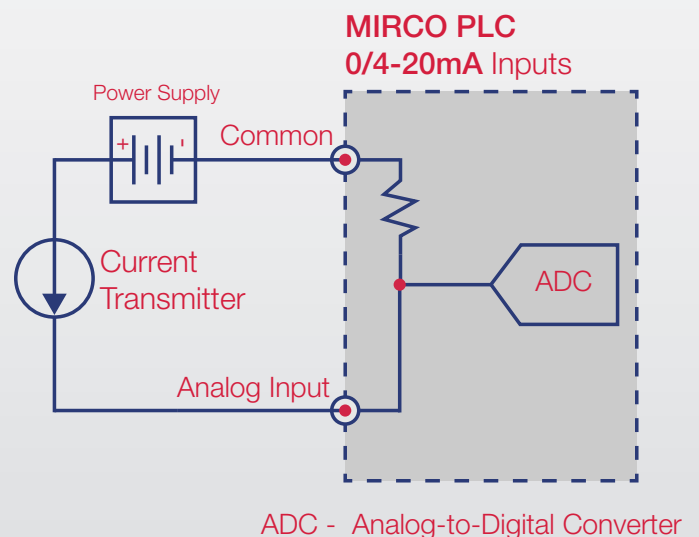
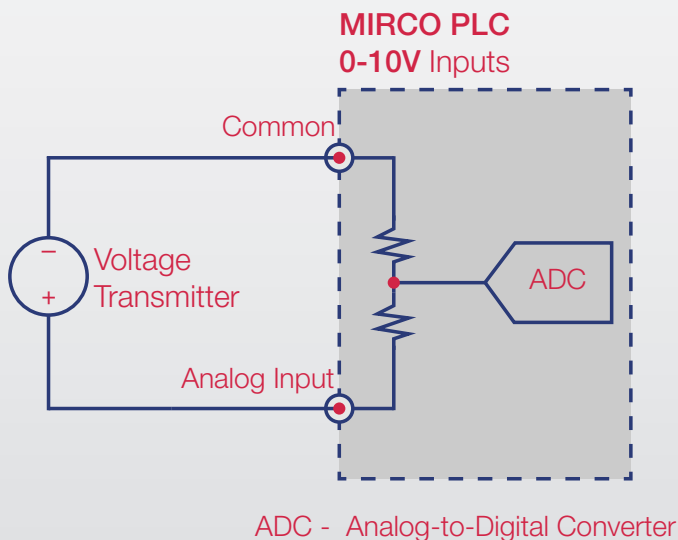

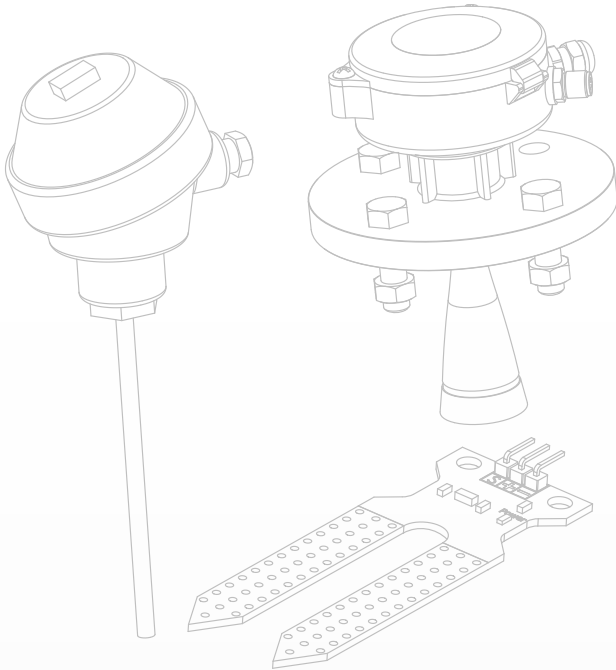

Analog Input Sensors



- Temperature Sensors
- Flow sensors
- Humidity sensors
- Potentiometers
- Pressure Sensors
- Tank Levels
- Load Calls
- Light Sensors
- Speed and position sensors

PT100 Inputs

Using the extension module It can be connected with one two-wire or three-wire Resistance Temperature Detector (RTD) PT100.

The RTD sensor is comprised of a resistor that changes value with temperature. The most common RTD by far is the PT100 385. This element measures 100 Ohms @ 0 degrees C (32 °F) and 138.5 Ohms @ 100 °C (212.0 °F). The temperature range for a PT100 inputs is within -50 to 200 °C (resolution 0.3 °C).

Using a two-wire connection the unit can not compensate error/ tolerance caused by the resistance in measurement loop. The measurement error of 1Ω is equivalent to an error of 2.5 °C. The three-wire technology can inhibit the influence of measurement results caused by cable length (ohmic resistance).

Two-wire connection

MIRCO PLC PT100 Inputs

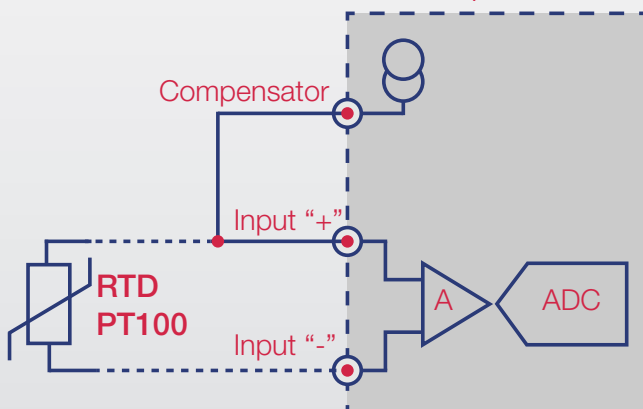

A - Amplifier; ADC - Analog-to-Digital Converter

Three-wire connection

MIRCO PLC PT100 Inputs

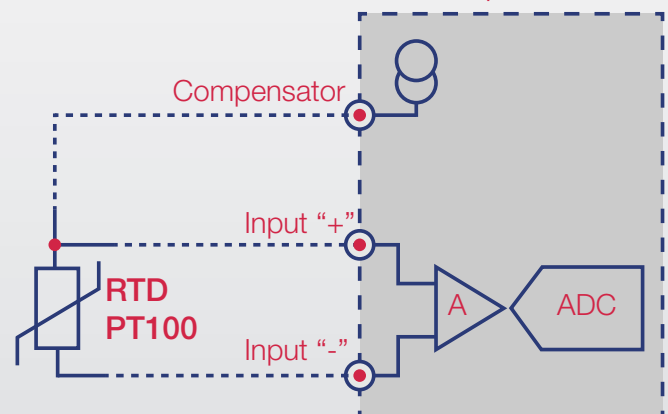

A - Amplifier; ADC - Analog-to-Digital Converter

Outputs

Digital Outputs

Digital output (DO) are for the ON/OFF in your control scheme. Some examples are the On/Off control of motors, lighting, solenoid valves, door locks.

All Rievtech PLCs have a number of digital outputs.

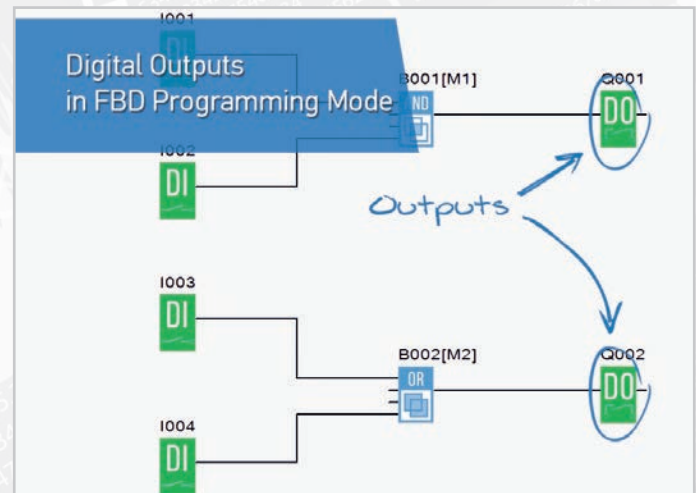

Relay Outputs

Existence of relays as outputs makes it easier to connect with external devices. A relay is non-polarized and typically it can switch either AC or DC.

Relay dry contacts are the quick choice since they are voltage independent and they provide an easy interface to a customer's system. Relays generally have a higher current rating than transistors, but have a mechanical life span that has to be considered. The maximum ON output current that can be switched by our Micro PLC is 10A for the resistance load and 3A for the inductive load.

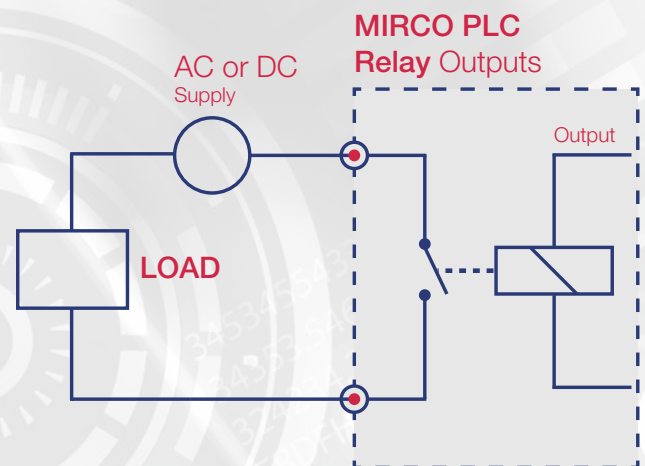

Transistor Outputs

Transistor type outputs can only switch a DC current.

Micro PLC digital outputs are sinking transistor outputs - which means that they provide the ground connection turn on a load. When switched on under program control, they complete the circuit to turn on any connected DC device up to 60VDC and 300mA.

They are smaller and thus offer higher I/O count per unit of circuit board real estate. You may also choose them for faster switching speeds and longevity over relays.

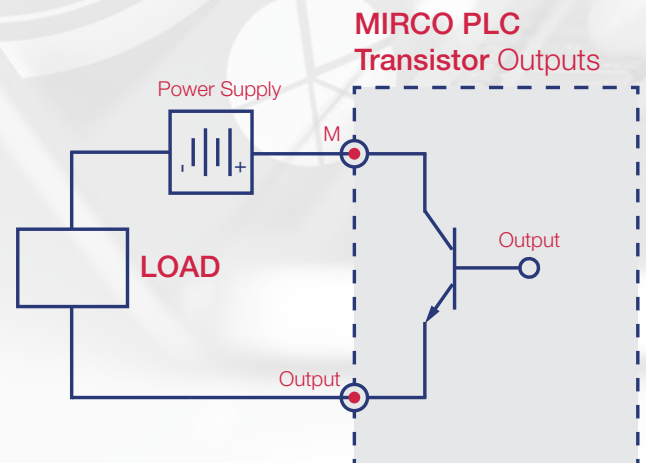

Analog Outputs

Analog output (AO) are for variable level or range of output between OFF or stopped and ON or full speed as for an electric motor for instance. Examples of analog outputs are a VFD (Variable Frequency Drive), a valve position actuator, and a industrial variable power supply.

The analog outputs (0-10V or 0-20mA) have a 10-bit digital resolution.

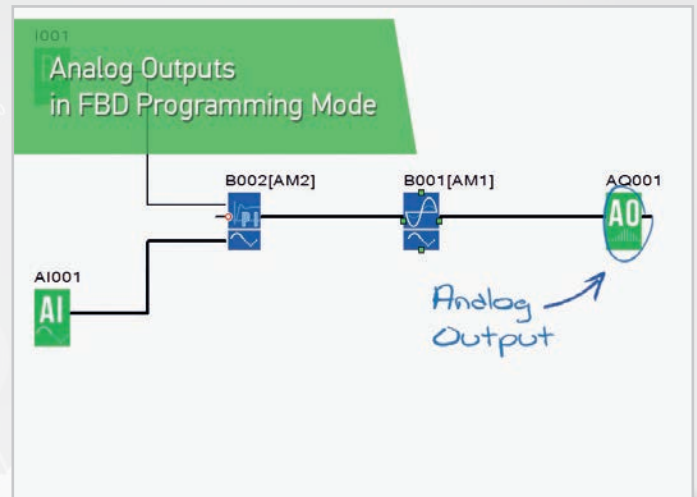

MIRCO PLC Analog Outputs

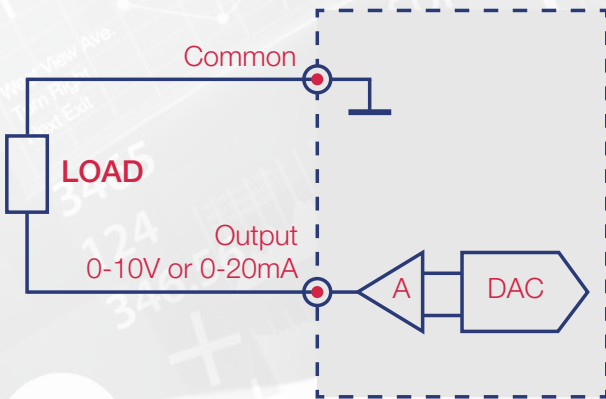

A - Amplifier; DAC - Digital-to-Analog Converter

Digital and Analog Output Devices



Motor starters
Contactors
Lamps
Alarm Hooters
Solenoid Valves
Coils
Pumps

Valves
Drives
Actuators
Positioners
Heaters
Motor Speed
Chart Recorders
Analog Meters

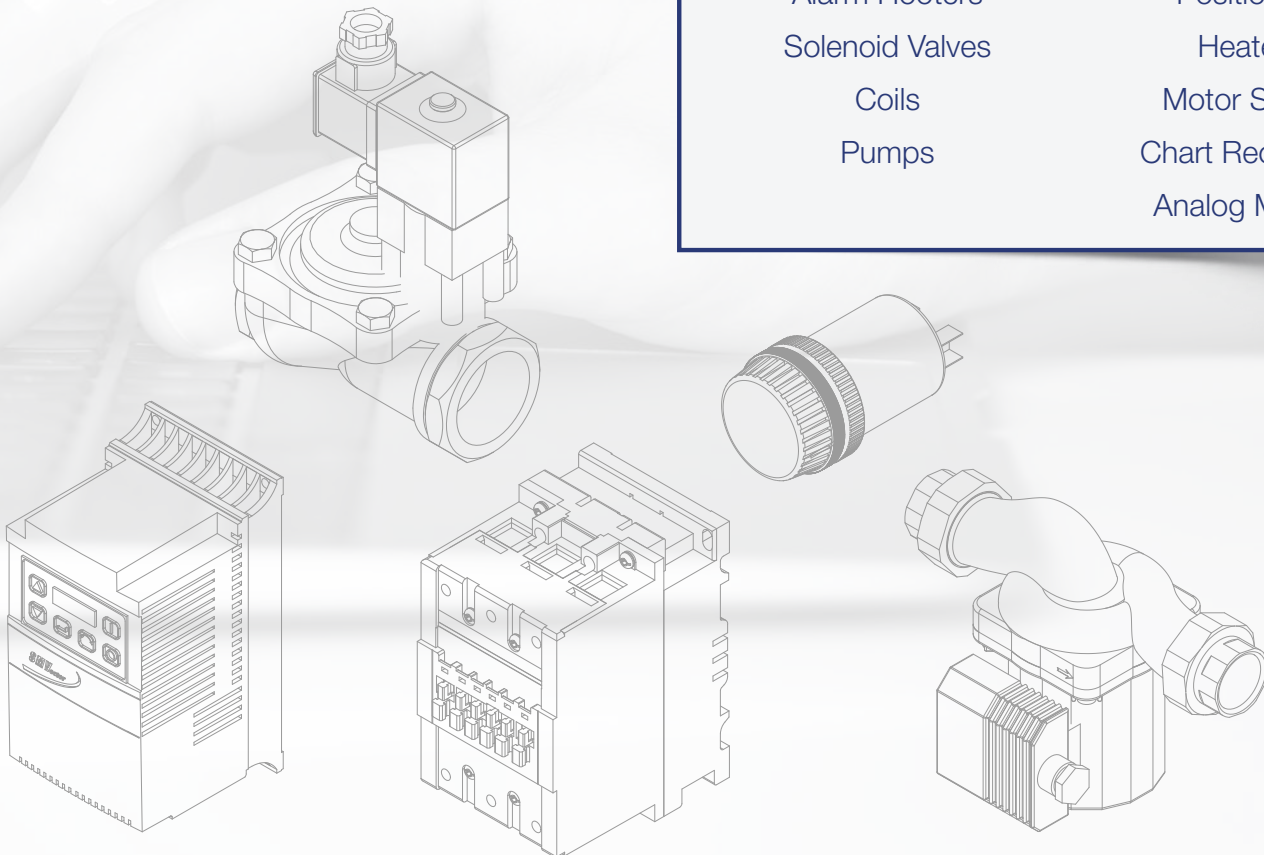

High Speed Inputs

Many machine control applications require various types of simple high-speed monitoring and control. These applications usually involve some type of motion control, or high-speed interrupts for time-critical events. The Rievtech Micro PLC solves this traditionally expensive problem with built-in CPU enhancements.

High Speed Inputs

The counting frequency of an ordinary PLC's inputs can only reach tens of Hz. If the frequency of the input signal is higher than that, it is necessary to utilize high-speed inputs and high-speed counters (HSC), otherwise loss or errors in counting may occur.

All DC models (except PR-6DC-DA-R and PR-12DC-DA-R-E) have 4 built-in high-speed inputs which can count pulses at a maximum rate of 60kHz for a single phase. This allows direct connection with a rotary encoder and counting input from the encoder. The Micro PLC can be used for various applications, such as speed measurement and high speed interval counting; by utilizing the input capture functions.

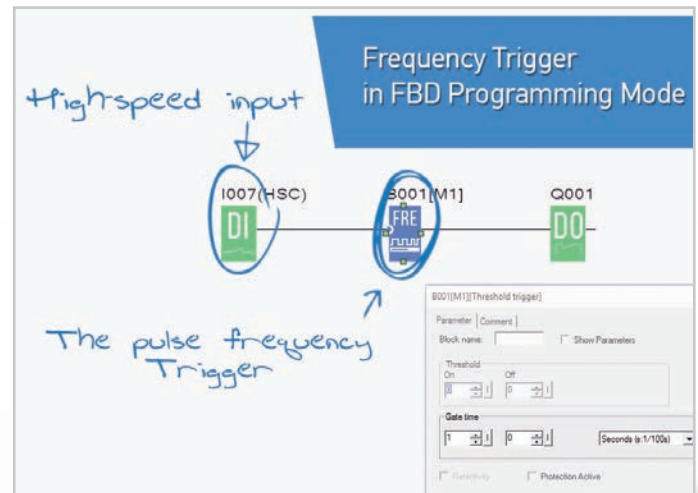

The encoder output pulse can be input to the high-speed counter to control such a high-speed operation.

Control an inverter by entering positional information with an encoder. Gather real-time production information and control with precision.

Measuring the Pulse Frequency

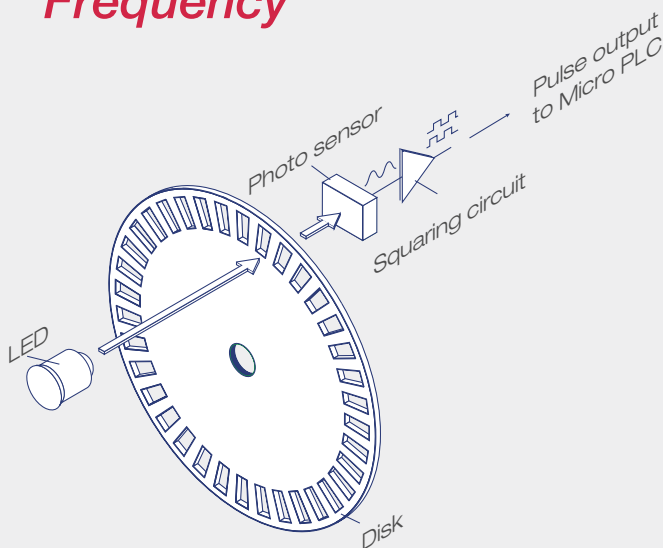

Pulse input in a specified period by a single instruction are counted, and the frequency is calculated

One useful application of the high speed input capability is to measure the speed of rotation of a motor.

A simple optical sensor, coupled with a rotating disk with slots fitted to the shaft of a motor can be fabricated economically. When the motor turns, the sensor will generate a series of pulses.

The frequency of this pulse train relates directly to the rotational speed of the motor and can be used to provide precise speed control.

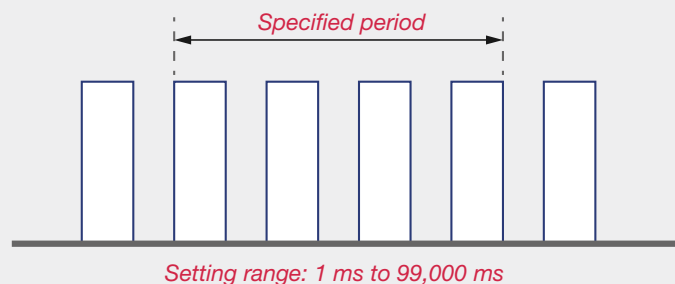

Measuring *Line Speed and Length* of film or paper on a production line

This application shows how to measure and calculate line speed and length of rolled film moving down a production line by the number of generated pulse and roll diameter from a rotary encoder.

The rotary encoder is connected to a rolling shaft on a film production line.

Using digital outputs allows send a command signal to cut a film or to send an alert to a signal tower.

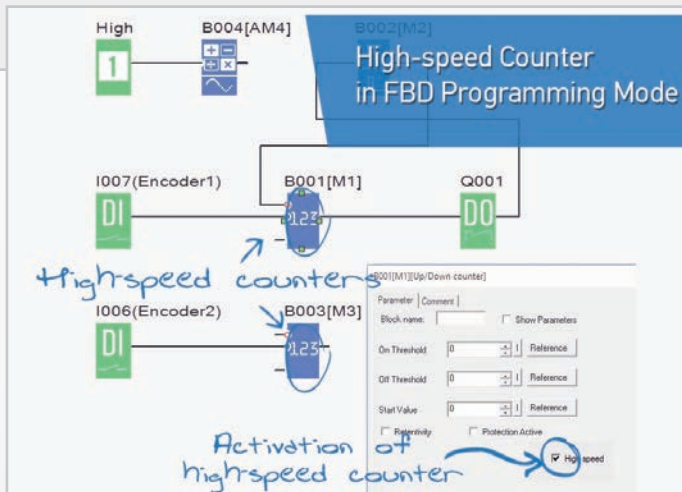
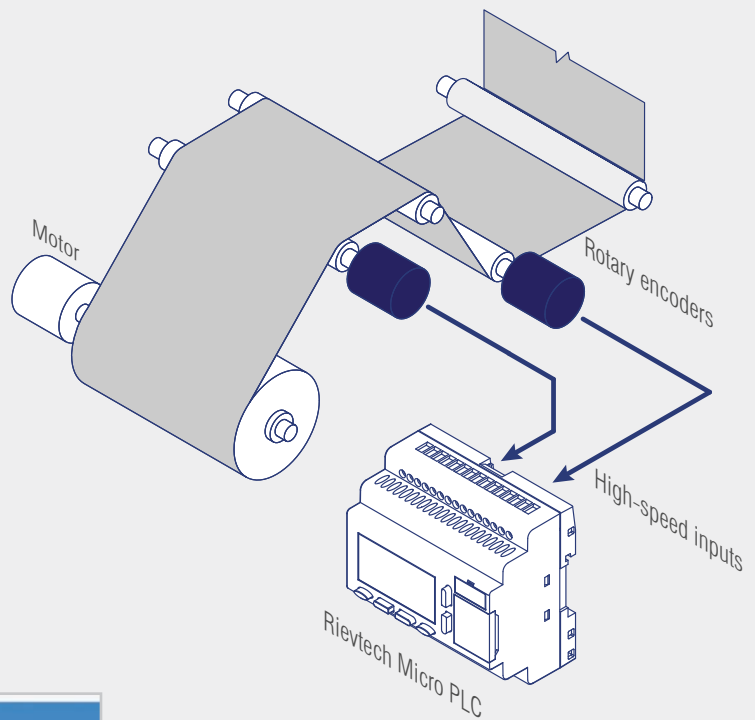

High Speed Outputs

High Speed Outputs

In PLCs that have transistor outputs, the terminal for output bits 0 and 1 can be used not only as a usual external output but as pulse output with up to 10kHz. The pulse output can be operated with dedicated instructions, allowing easy control based on pulse train output and pulse width modulation.

Pulse Train Output

Positioning control with servo motors and stepper motors is possible without specialized units.

The High-speed Output (HSO) generates output pulse trains suitable for open-loop control of a single-axis motion positioning system. It generates pulse (stepper increment) and direction signals which you can connect to motor drive systems and perform various types of motion control.

Error detection can be available by using the high-speed counter in combination. Unexpected incidents, such as errors in the driving system, can be detected by setting the counter so that it counts the feedback pulses from an encoder during positioning.

Simple positioning control, fine tuning of conveyor's moving distance, etc. are possible by pulse train output.

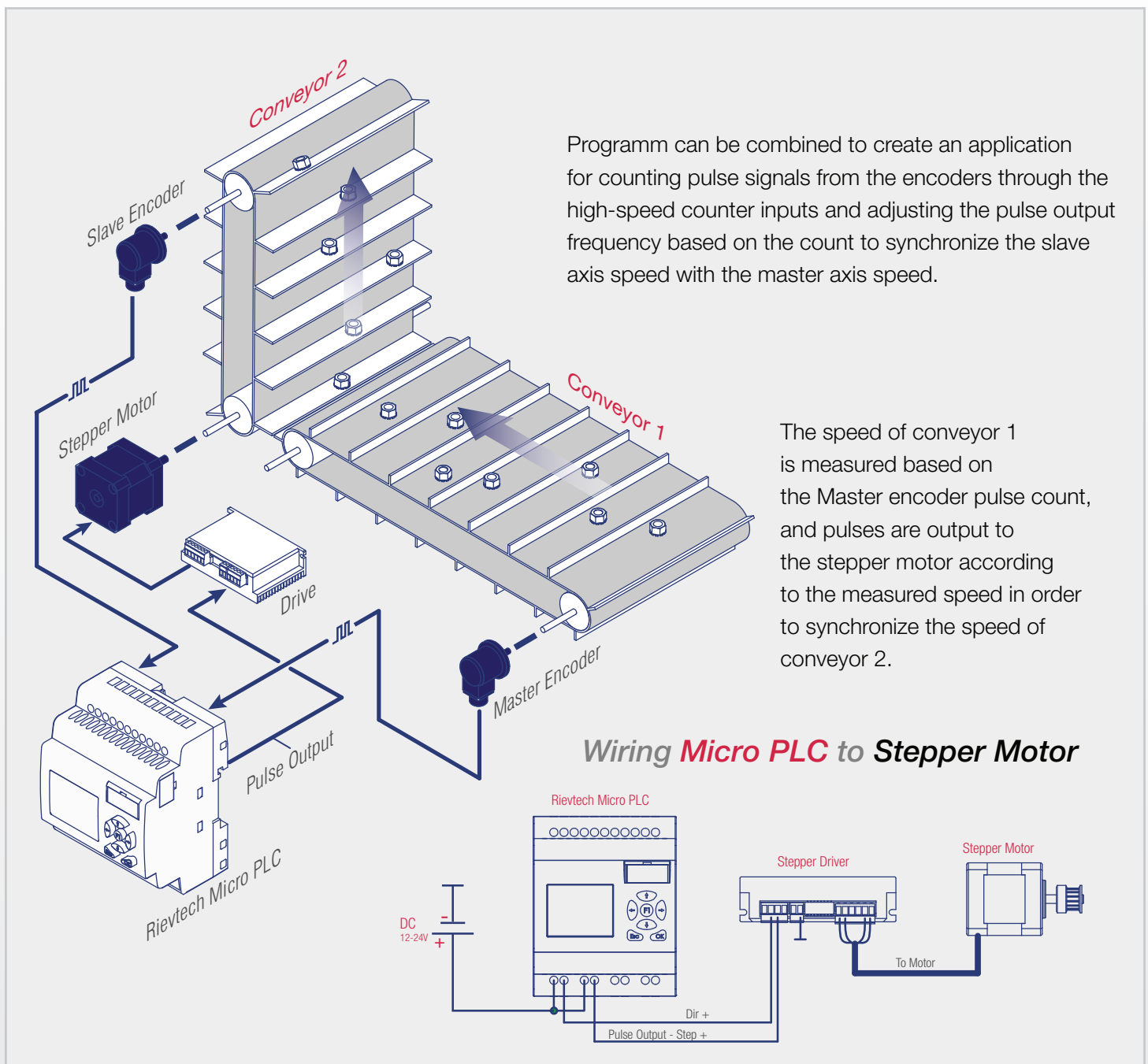

Pulse-Width Modulation (PWM) Output

The pulse output of the Micro PLC can also serve as a PWM output port.

Pulse-Width Modulation (PWM) is a highly efficient and convenient way of controlling output voltage to devices with large time constant, such as controlling the speed of a DC motor, the power to a heating element, light brightness control or the position of a proportional valve. PWM works by first turning the output to full voltage for a short while and then shutting it off for another short while and then turning it on again and so on in accurate time intervals.

The advantage of using PWM is that you can easily amplify the drive current to a larger load such as larger permanent magnet DC motor by using low cost DC Solid-State Relays (SSR) to boost the current switching capability. Using SSR has the added advantage of isolating the CPU from the high current load.

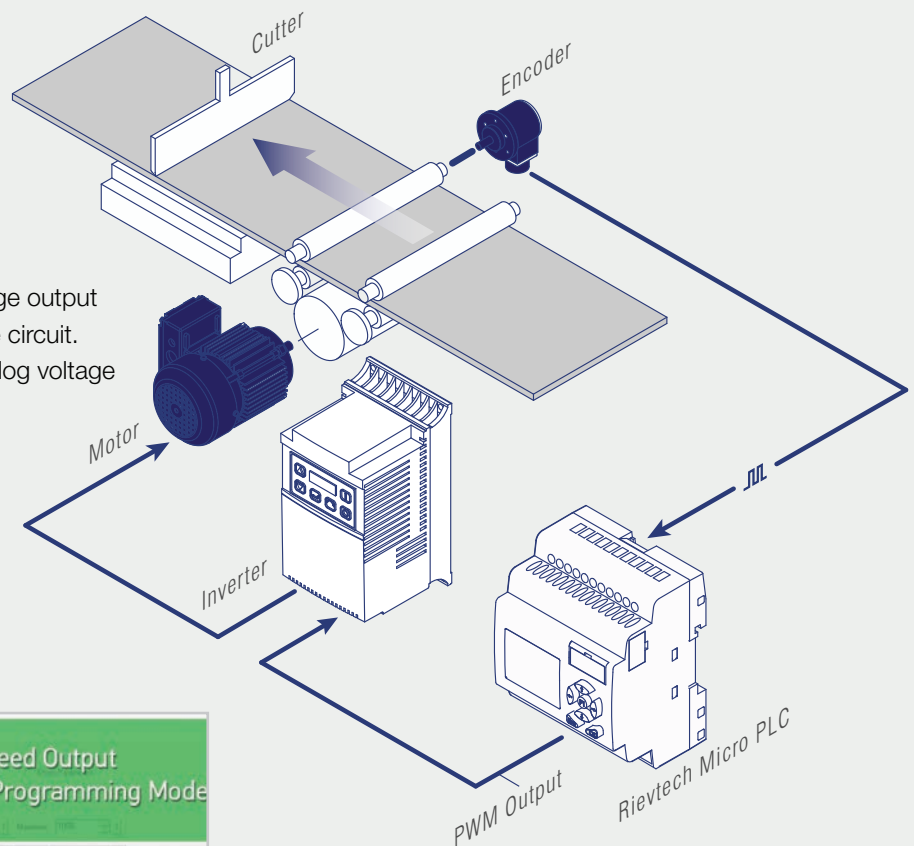
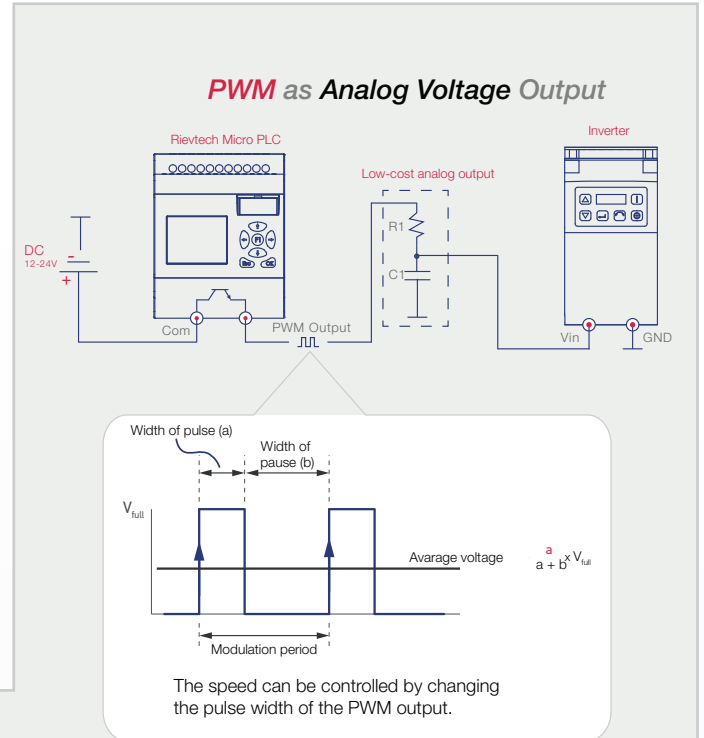

The output can also serve as an analog voltage output when a smoothing capacitor is inserted in the circuit. One of the application examples such an analog voltage output is an inverter speed control.

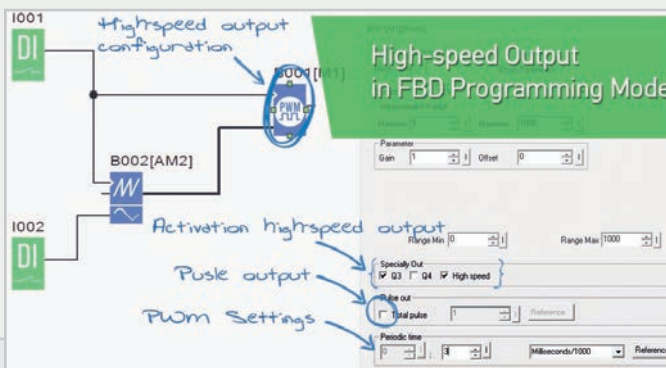

Other Useful Functions

LCD and Keypad

Rievtech PLCs (except PR-6 and PR-12 Economy Series) have a built-in LCD display with a brighter, higher contrast screen you can adjust to your own preference. System status — input, output, analog values, timers and counters — can be monitored through the 4x16 LCD screen or you can display a predefined message with up to 64 characters. Non-LCD versions are also available.

System menu is available in multiple languages.

Checking or changing some device values Micro PLC does not need to be connected to a PC.

Making precise on-line adjustments to internal blocks, such as timers, counters while the PLC is operating.

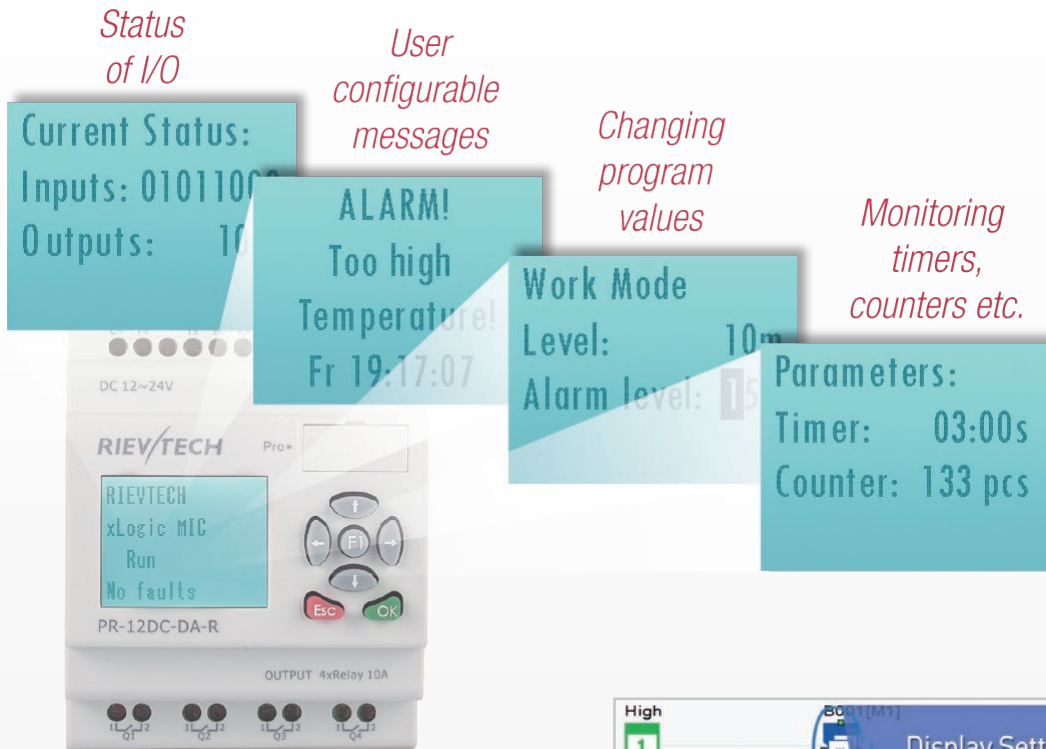

Potential Uses

The potential uses for the LCD display and keypad vary widely. An operator can change values for setting up batch processes or machine timing for manufacturing different products, etc. Maintenance personnel can interface in the control cabinet to identify machine problems. LCD messages can be preprogrammed for process events or alarms.

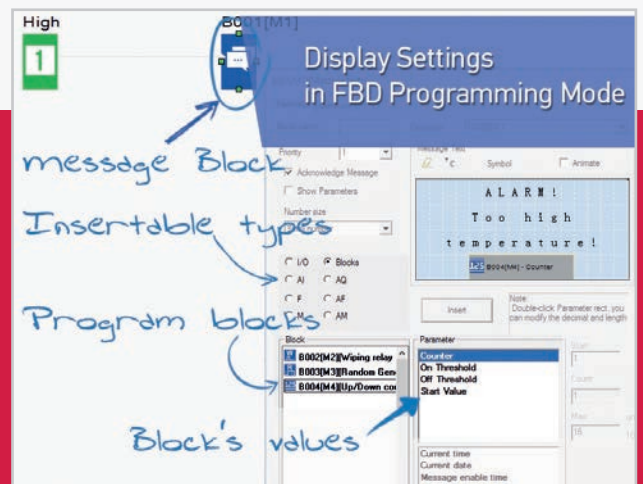

Operational Control Buttons Program with just the push of a button! Micro PLC control buttons can be used to program, modify and change preset parameters. The four cursor keys can also be configured as inputs as needed.

Real-Time Clock with Backup

A real time clock (RTC) has been built in all PR models.

No matter whether the PLC is switched on or off (up to 20 days when power is off), the RTC will keep accurate time. It provides 7 units of time data-week, year, month, day, hour, minute and second. For applications that require the RTC to continue running more than 20 days after power off you can purchase a PR-Battery accessories or insert a 3V on-board lithium battery in the inner battery socket (Only for PR-24 Series). Users can take advantage of the real time clock to do 24 hour controls throughout the year (for example, businesses or factories can switch lights on and off at set times each day, control gate access, and do pre-cooling and pre-heating before business or operations begin).

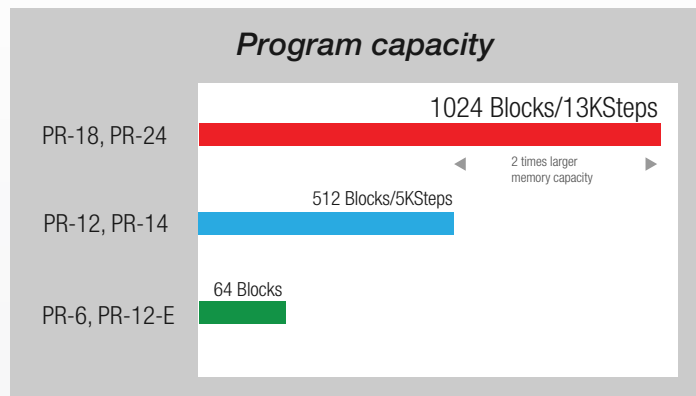
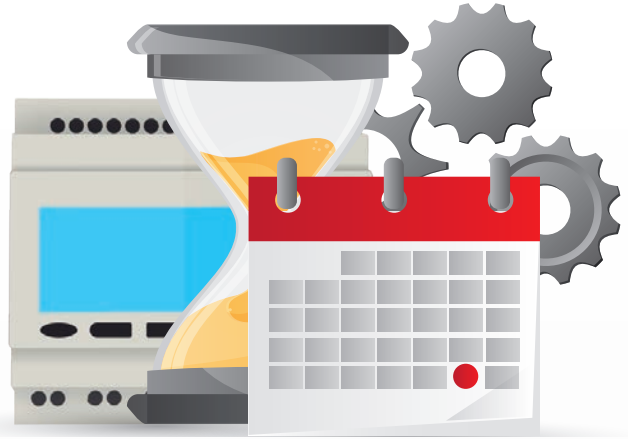

Large Program Capacity (Largest in its class)

Your PLC needs enough storage space to handle the amount of tasks you are going to assign and it doesn't hurt to have a little extra for future needs.

Rievtech Micro PLC is equipped with abundant memory capacity. With 1024 blocks (13k Steps) (For PR-18, PR-24) of logic controls programming, complex PLC programs can be constructed without much restriction.

Data Logging to a Micro SD Card

Data-logging is the process of collecting, in real time, determined process parameters such as conditions, values, as well as the time that said information is collected, or noted. Having historical data available to you when trying to find or correct an issue can make a huge difference. PR-MEMORY allows you to log up to 2GB of tag data. This data is saved in .txt format on a removable micro SD card and can be easily downloaded to your PC.

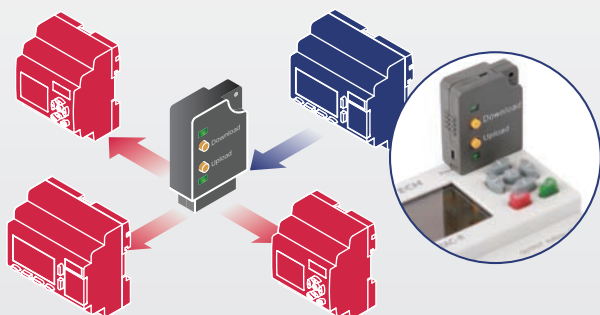
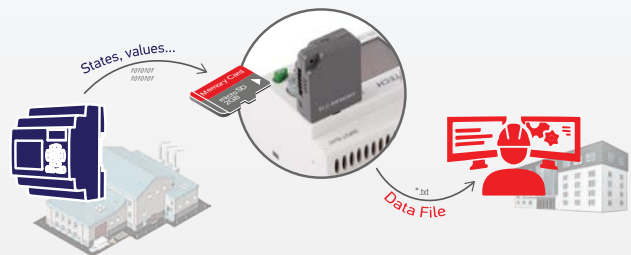

Transport Programs between PLCs with PR-Copier

Experience true program file portability using our accessories PR-Copier. Quickly backup existing programs, restore or download new programs, and easily transfer programs between PLCs.

Expandability

For PR-14, PR-18 and PR-24 Series, the number of I/O points can be increased up to 140DI or 80AI and 136DO or 34AO (up to 280 I/O in total) by adding digital I/O units to the basic unit. Up to 16 digital I/O units can be added.

Expansion I/O modules extend the capabilities of the PR-14, PR-18 and PR24 controllers by maximizing flexibility of the I/O count and type. The modular, rackless design enhances cost savings

and reduces replacement parts inventory. Modules can be either DIN rail or panel mounted.

230V CPUs can be expanded with analog modules.

You can use such modules: PR-E-16AC-R, PR-E-16DC-DA-R, PR-R-16DC-DA-TN, PR-E-AI-I, PR-E-PT100, PR-E-AQ-VI, PR-RS485



Modbus-Compatible

Rievtech Micro PLCs are compatible with the world's Modbus* de facto standard and can serve as both Modbus master and slave RTUs, which are ideal for air conditioning or temperature control etc.

Modbus is the most popular industrial protocol being used today, for good reasons. It is simple, inexpensive, universal, and easy to use. The Micro PLC can be networked to other Micro PLCs, data input devices (barcode readers, weight scales, etc.), and/or data output devices (serial printers, serial text displays, etc.). It is also possible to network the Micro PLC to other 3rd party PLCs and devices that have the ability to communicate using the Modbus RTU protocol.

MODBUS Master-Slave Communication

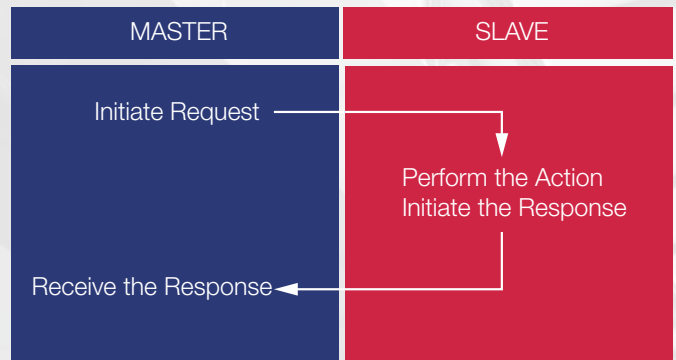

The default device address is 1, but can be configured to any desired address via xlogicSoft.

* Protocol developed by Modicon Inc., an American company

RS232 (USB) Port – Serial COM0

All Micro PLCs have built-in the universal communication port with optional USB or RS232 interface.

USB interface complies with standard functional specification of USB1.1

Besides providing the standard RS232 interface, the universal port also provided USB interface since more and more notebook computers are using USB port to replace COM ports due to light weight and thickness considerations.

To connect to the RS232 port, use an RS232 cable with galvanic isolation or USB Cable to connect to USB port of PC.

RS232 ports are commonly used for interfacing hardware HMI panels and other devices through Modbus RTU/ASCII communications.

RS232 Port can be used as a Modbus RTU master or slave protocol device, or handle ASCII data In or Out (ASCII stands for American Standard Code for Information Interchange and defines a

MODBUS Master Command

READ DATA	WRITE DATA
01 Read Coils 0x 1x	05 Write Single Coil
02 Read Discrete Input 0x	06 Write Single Register
03 Read Holding Registers 4x	15 Write Multiple Coils
04 Read Input Registers 3x	16 Write Multiple Registers

character encoding method for text that is used in computers and other communication devices).

With special accessory – PRO-RS485 Cable, the universal port can serve as RS485 Port.

RS232 Cable



USB-Cable



RS-485 PRO Cable



Communication

RS485 Port - Serial COM1/COM2

RS485 ports are commonly used in multi unit systems and for longer distance communications.

RS485 is currently a widely used communication interface in data acquisition and control applications where multiple nodes communicate with each other.

All devices are connected in a bus structure (line). RS232 provides only point to point connection function while RS485 provides connection for multiple stations. Up to 32 stations (master or slaves) can be linked up in one segment. Half-duplex transmission system allowing transmission distances of up to 1.2 km.

Models PR-14 and PR-24 have a built-in RS485 Port with galvanic isolation. In addition to all models (except PR-12 series), you can connect an additional expansion module PR-RS485.

Serial COM Port Configuration

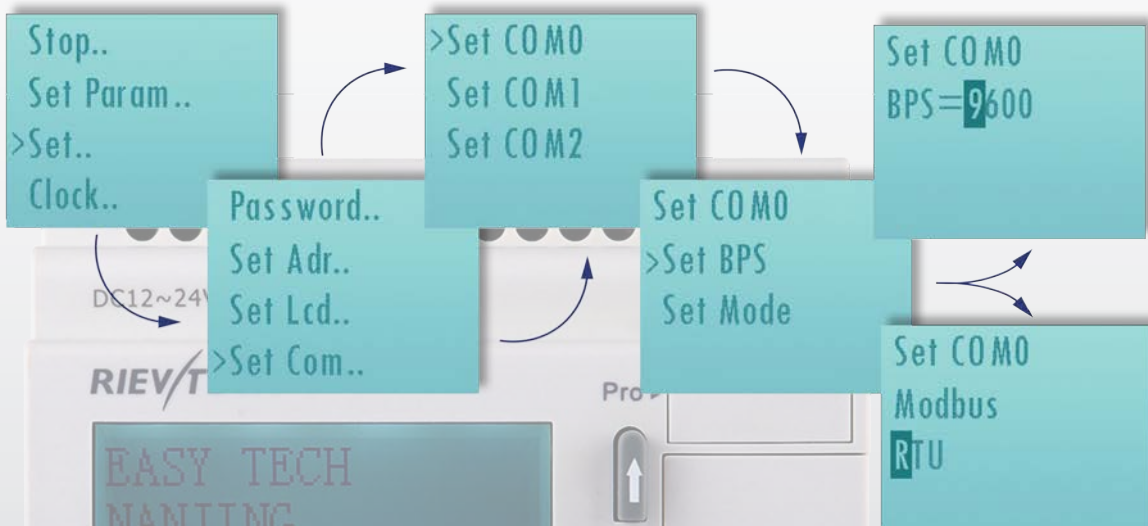

Universal Port - Serial COM0
Can work as RS232/USB



RS485 Port - Serial COM1
Except PR-12 Series



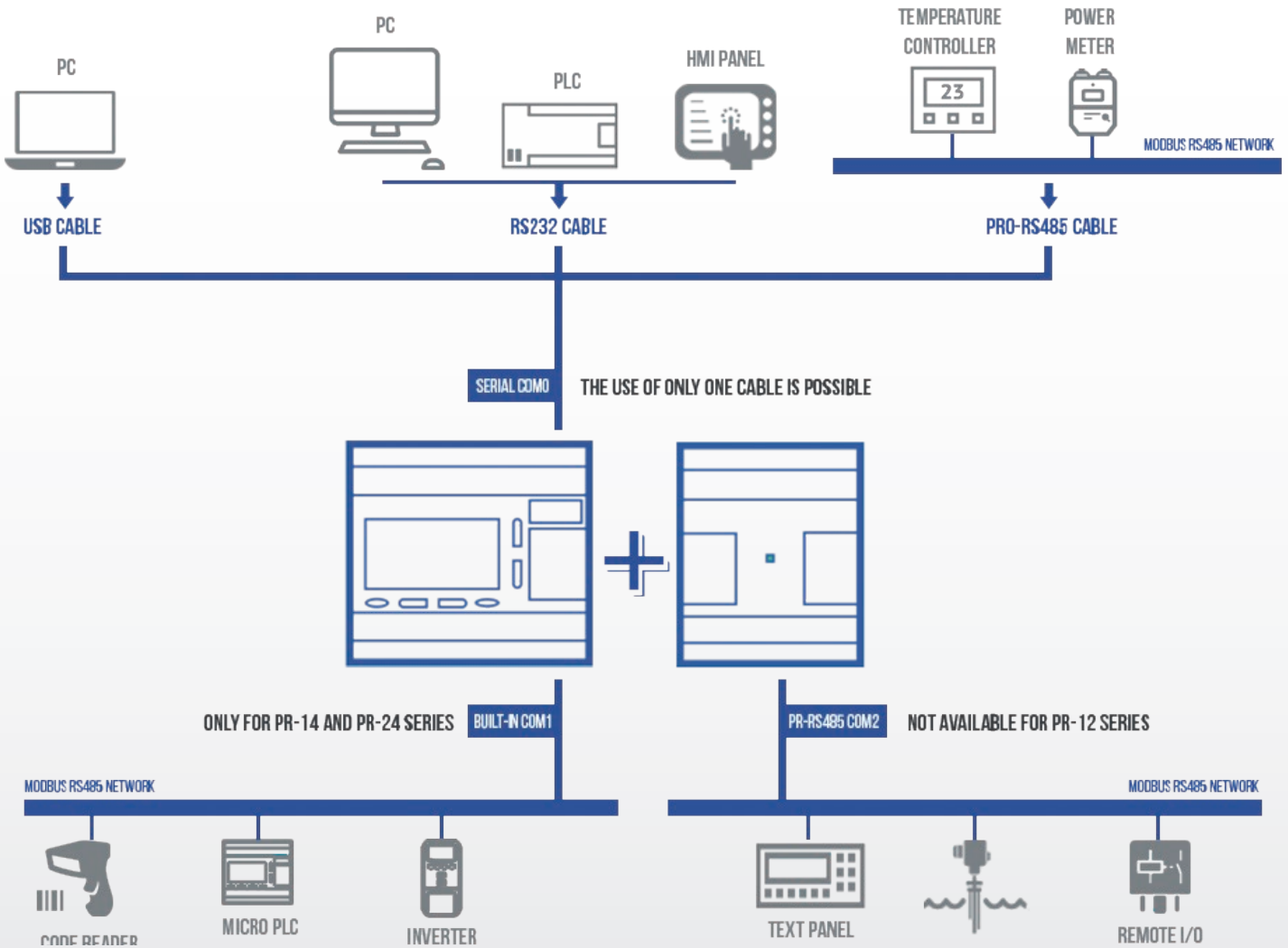

RS485 Built-in Port - Serial COM2 Only for PR-14 and PR-24 Series

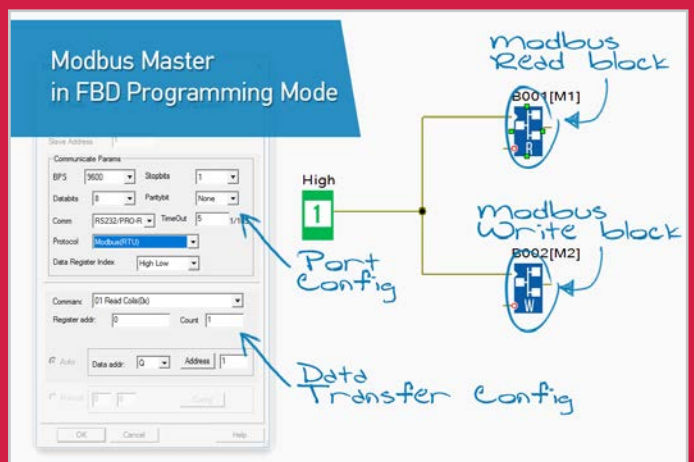

Software

Easy programming – step by step

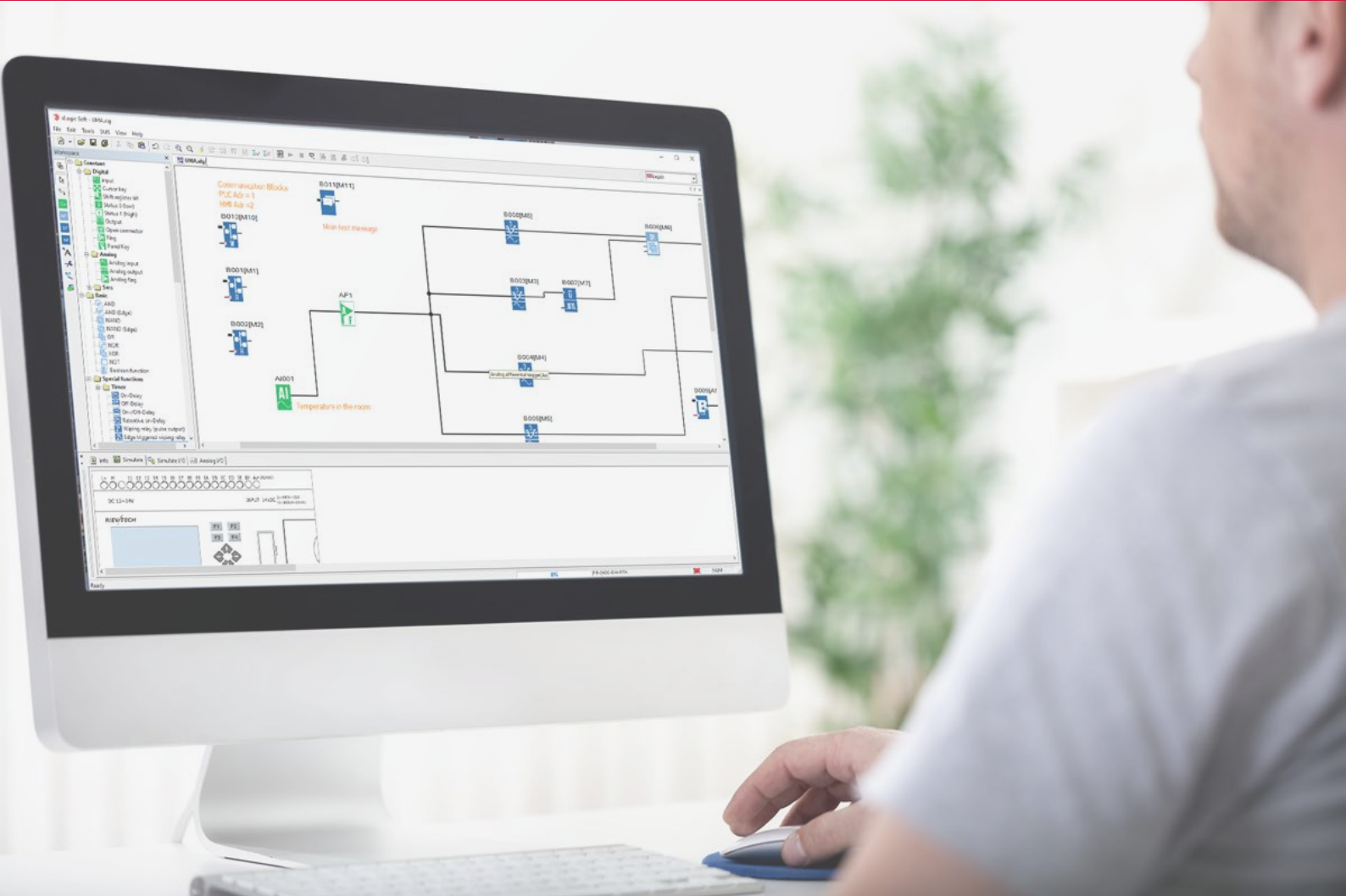

Use xLogicSoft for online monitoring, program upload/download, controlling PLC stop, adjusting PLC real-time clock, modifying password protection, modifying communication port parameters.

The software is intuitive and simplifies your work. You do not need any in-depth programming knowledge.

xLogicSoft is the developing environment which supports several languages: English, French, Russian, German, Spanish, Chinese, Poland, Czech.

01 CONFIGURATION HARDWARE



02 DRAG & DROP BLOCKS



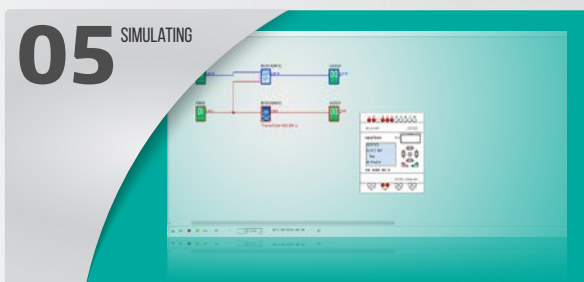
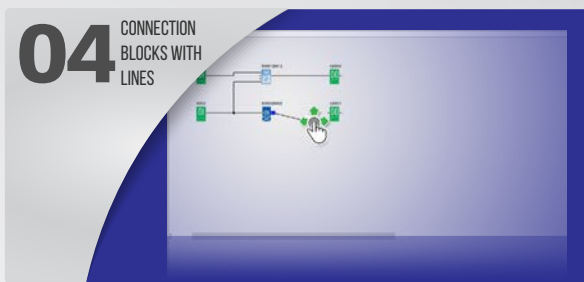

The programming software xLogicSoft allows easy and transparent programming of the MicroPLC with a PC.

Up to 1024 (64 for PR-6 and PR-12 Economy; 512 for PR-12 and PR-14 Series) function blocks can be stored inside the program memory of the Micro PLC. Stored programs cannot be lost even during a power loss. Therefore back up batteries are not needed. With the simulation tool, the set up can be tested on the PC before commissioning.

Control tasks can be solved easily with the function blocks available in the library (over 70 different instructions). Programming codes in a high-level program language are not required. Simply place the corresponding function blocks and link them with other function blocks according to the required control function.

Download Now!

Download the FREE xLogicSoft software and a number of complete programs for applications from our website – rievtech.com/download

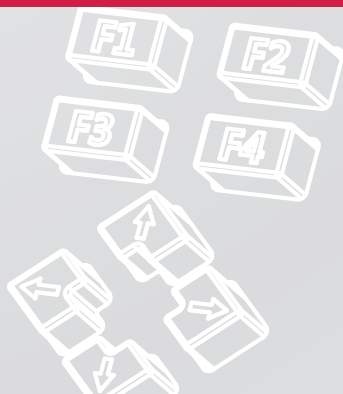

Software

Easy configuration – xLogicSoft

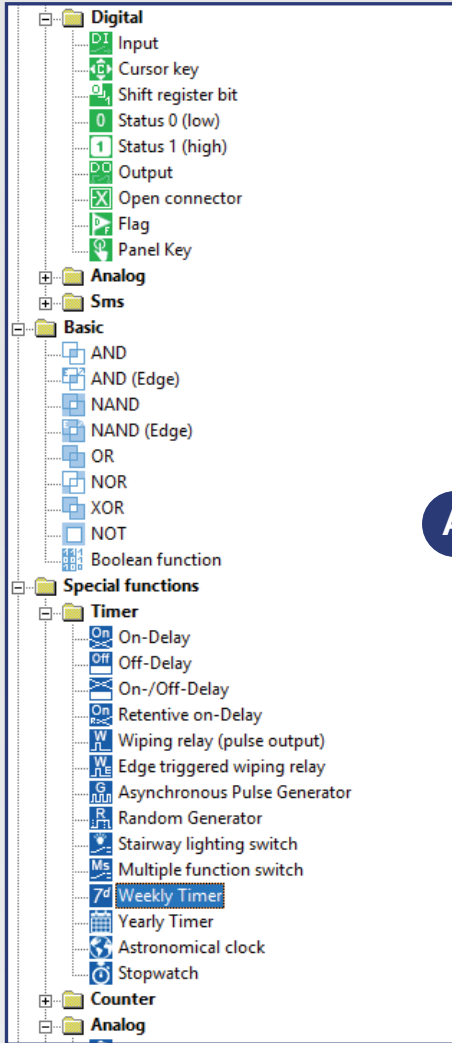

A **A Rich Set of Functional Blocks**
 With a whopping 100 different Function Blocks available, your ability to create programs is limited only by your imagination. New application-specific functions such as pump switching, defrost, multicomparator, absolute humidity and others.

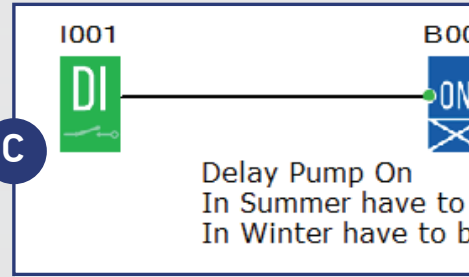

A

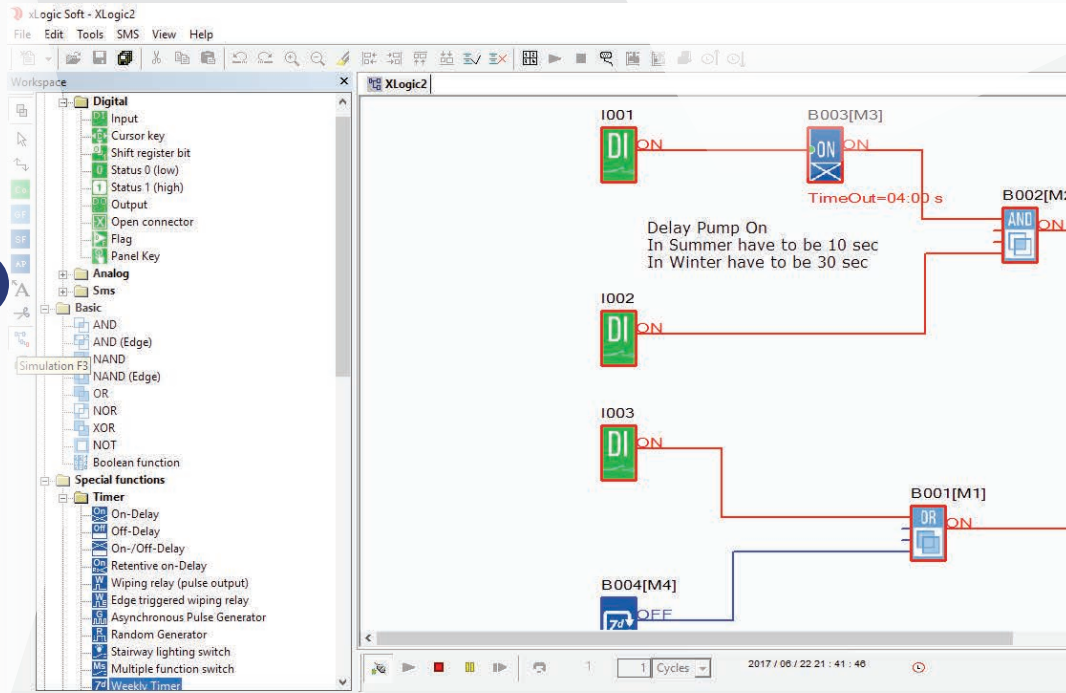

C

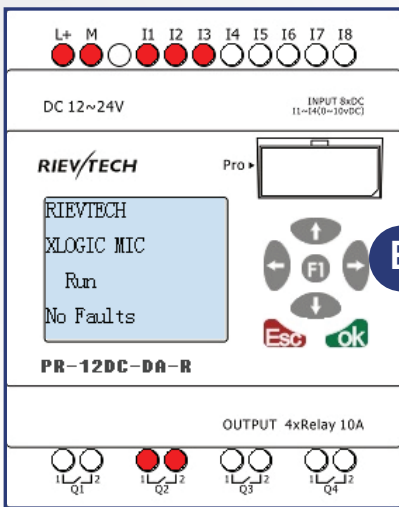

B



B **Quick debugging without a PLC**
 Our software simulator, simulates a program in operation before you connect your PLC. During programming or the programming is completed, you can run PLC program in the simulation without online to check the program execution is correct or not. It can reduce on-site commissioning time greatly, reduce debugging difficult and improve debugging efficiency.

C Program Comments

When you transfer your program to the PLC, you can include any program comments too. With comment data, you can review programming codes for clarification and streamlined maintenance.

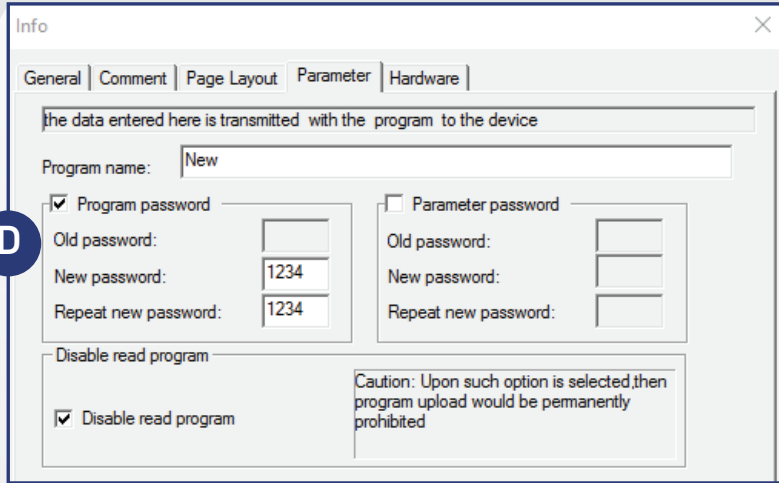

D

D Program upload and change protection

User programs can be protected from unauthorized copying and changing by disabling program upload and change using xLogicSoft. These functions are helpful for users who manage original programs on a PC.

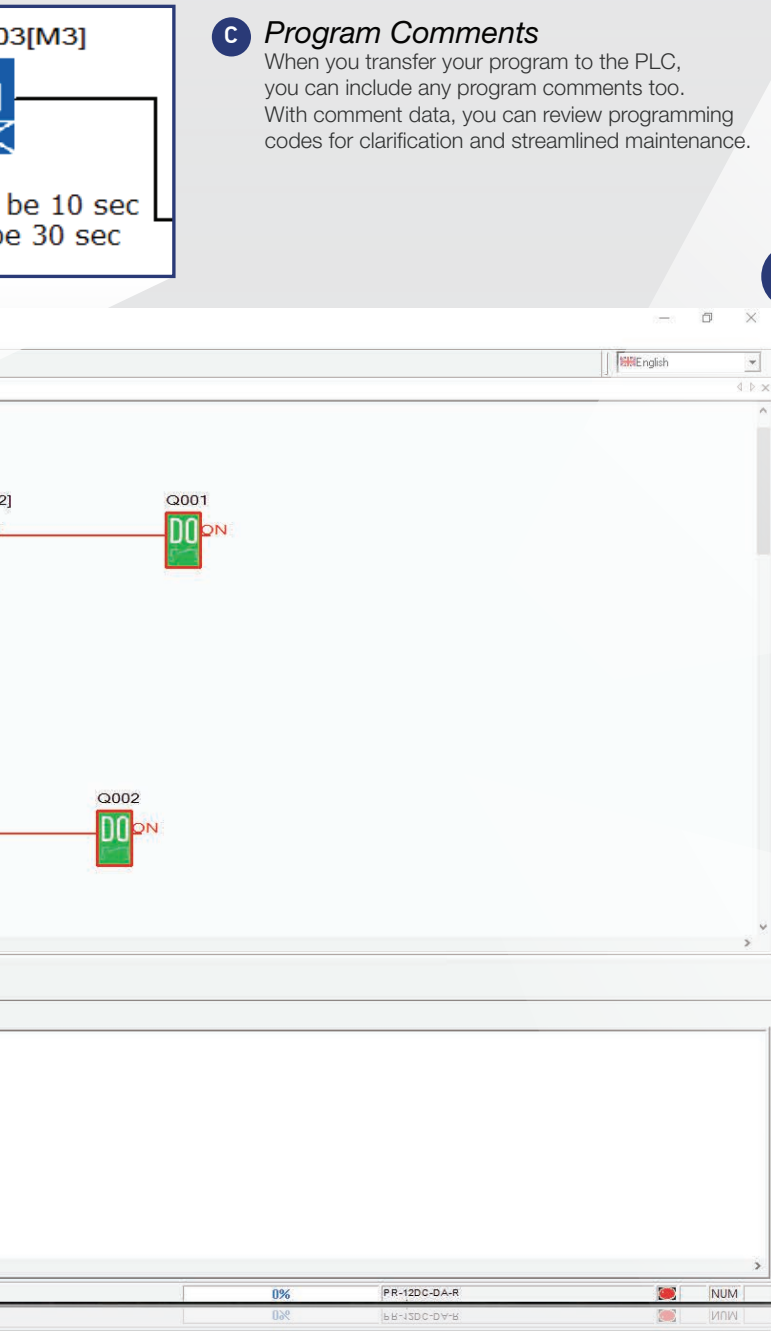

E

E Trend monitoring + Operation Log

Real time monitoring without machine stoppage. Program and element on/off status can be monitored in real time. You can monitor the statuses of the devices assigned to built-in functions: I/O, timers, counters, status of blocks, frequency, analogue values, display messages, communication. The changing value of specific device can be monitored and saved as a file.

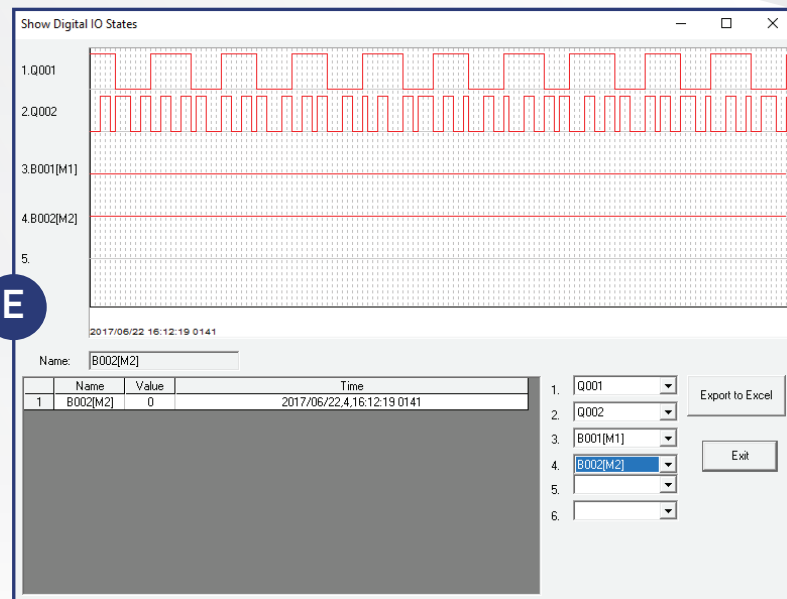

Software

Easy configuration – xLogicSoft

Constant Blocks

Digital

Digital Input	
Cursor Key	
Shift Register Bit	
Status 0 (Low)	
Status 1 (High)	
Digital Output	
Open Connector	
Digital Flag	
Panel Key	

Analog

Analog Input	
Analog Output	
Analog Flag	

Basic Blocks

AND	
AND (Edge)	
NAND	
NAND (Edge)	
OR	
NOR	
XOR	
NOT	
Boolean Function	

Special Blocks

Timers

On-Delay	
Off-Delay	
On-/Off-Delay	
Retentive On-Delay	
Wiping Relay (Pulse Output)	
Edge Triggered Wiping Relay	
Asynchronous Pulse Generator	
Random Generator	
Strairway Lighting Switch	
Multiple Function Switch	
Weekly Timer	
Yearly Timer	
Astronomical Clock	
Stopwatch	

Counters

Up/Down Counter	
Hours Counter	
Threshold Trigger	

Analog

Analog Comparator	
Analog Threshold Trigger	
Analog Amplifier	

Special Blocks

Analog

Analog Watchdog	
Analog Differential Trigger	
Analog MUX	
PI Controller	
Analog Ramp	
Analog Math	
Long Datas Math	
Analog Math Error Detection	
Analog Filter	
Max/Min	
Average Value	

Miscellaneous

Latching Relay	
Pulse Relay	
Message Text	
SoftKey	
Shift Register	
PWM	
Modbus Read	
Modbus Write	
RH Math	
Data Latching Relay	
Long Data Latching Relay	

Special Blocks

Miscellaneous

Memory Write	
Memory Read	
Word to Bit	
Bit to Word	
Device Reset	
Comport Status	

Application Blocks

CAM Control	
Angular CAM Timer	
Pumps Management	
Defrost	
Comparison of 2 Values	
Multicompare	
Compare in Zone	
Conversion Word Bits	
Conversion Bits Word	
Demultiplexer	
Multiplexing	
Multiplexer	
Square Root	
Sin/Cos	
Absolute Humidity	

Block Input Types

- ▶ **En, Validation** - This input enables a block function. When this input is "0", other signals to the block will be ignored.
- **Trg** - This input is used to trigger the start of a function
- **R** - Reset. The reset input R takes priority over all other inputs and resets the outputs.
- ▶ **Set** - A signal at input S sets the output to logical "1"
- ▶ **Fre** - Frequency signals to be evaluated are applied to this input.
- ▶ **Forward** - The input is used to control cam progress.
- ▶ **Reverse** - The input is used to control backward CAM movement.
- ▶ **Value** - The input, whose type is Integer.

Modbus Addresses

DI	1x	0-143	BIT	R
C	1x	256-259	BIT	R
DO	0x	0-137	BIT	R/W
M	0x	256-1279	BIT	R
DF	0x	1536-1791	BIT	R/W
REG	4x	0-1023	LONG	R/W
AI	4x	1024-1159	SHORT	R
AO	4x	1280-1313	SHORT	R/W
AM	4x	1536-2559	SHORT	R
AF	4x	3072-3327	SHORT	R/W
HEG	4x	2560-3071	WORD	R

R - Only Read
R/W - Read and Write

6

I/O

Not Expandable



PR-6

Model: PR-6AC-R **AC**Model: PR-6DC-DA-R **DC**

Specifications

Item	PR-6AC-R	PR-6DC-DA-R
Nominal voltage	AC 110V-240V	DC 12-24V
Operating limits	AC 85 - 265V	DC 10.8-28.8V
The main frequency range	47-63Hz	-
Immunity from micro power	-	Typ 5 ms
Max startup current	-	Max 0.25A
Isolation voltage	1780V AC	-
Max absorbed power	34 mA (85V AC) 26 mA (265V AC)	1.1 W (10.8V DC) 1.2W (28.8V DC)
Protection against polarity inversions	Yes	
Input No	4 (I1-I4)	
Digital input	4 (I1-I4)	
Analogue input	-	4 (I1-I4) (0..10V DC)
Input voltage	AC 110-240V	DC 0-28.8V
Input signal 0	AC 0-40V <0.03mA	< 5V DC <0.1mA
Input signal 1	AC 79-240V >0.06mA	>8 V DC >0.3mA
Input current	-	0.4mA @ 10.8V DC 0.5mA @ 12.0 V DC 1.2mA @ 24 V DC 1.5mA @ 28.8 V DC
Response time	0 to 1: 120V AC : Typ. 50 ms 240V AC : Typ. 30 ms 1 to 0: 120V AC : Typ. 90 ms 240V AC : Typ.100 ms	0 to 1: Typ. 1.5 ms 1 to 0: Typ. 1.5 ms
Maximum counting frequency	Typ: 4 Hz	
Sensor type	Contact or 3-wire PNP	
Input type	-	Resistive
Isolation between power supply and inputs	-	
Isolation between inputs	-	
Protection against polarity inversions	Yes	-
Measurement range	-	DC 0-10V
Input impedance	-	Min 24KΩ Max 72KΩ
Input voltage	-	28.8 V DC max
Resolution	-	9bit 0.015V
Accuracy at 25 °C	-	± (Max 0.03V)
Accuracy at 55 °C	-	± (Max 0.06V)
Isolation between analog inputs and power supply	-	
Cable length	-	10 m max shielded & twisted

Item	PR-6
Memory	64 Functional Blocks
Data Retentivity	-
Program Backup	10 years
RTC	Backup at 25 °C: 20 days, RTC accuracy : MAX ±2S/day
Cycle time	0.6ms - 8.0ms
Expansion	-
Communication	TTL interface, 1 Program/RS232 port. Modbus RTU/ASCII only can serve as slaves
Certificate	
Operation Temp	-20 °C .. +55 °C
Storage Temp	-40 °C .. +70 °C
Protection	IP20
Dimensions	48*90*64 (Unit, mm) 2DIN
Installation	35mm-DIN rail or screw for installation
Weight	Approx. 180g

Item	PR-6AC-R	PR-6DC-DA-R
Output No	2 (Q1-Q2)	
Output type	Relay output	
Continuous current	Resistive load 10A/Inductive load 2A	
Max breaking voltage	AC 250 V DC 110 V	
Max allowable power force	1250VA 300W	
Electrical durability expectancy	105 Operations at Rated Resistive Load	
Mechanical life	107 Operations at No Load condition	
Built-in protections	Against short-circuits: None Against overvoltages and overloads: None	
Response time	Operate Time : 15 ms max Release Time : 10 ms max	
Mechanism	10Hz	
Resistor/light load	2Hz	
Sensitive load	0.5Hz	

I/O circuit diagrams

[Digital Input - Power AC]

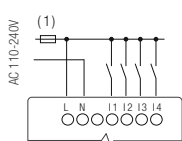

[Digital Input - Power DC]

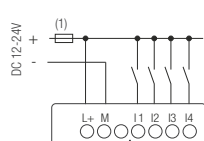

[DC analog inputs 0-10V - Power DC]

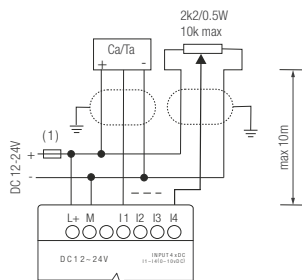

[Relay Outputs]

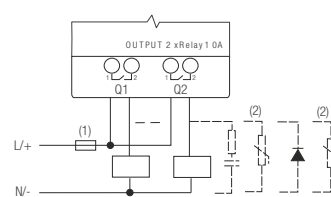

(1) - Fuse, circuit-breaker or circuit protector
(2) - Inductive load;

12
I/O
Not Expandable



PR-12 Economy

Model: PR-12AC-R-E **AC**

Model: PR-12DC-DA-R-E **DC**



PR-12

Model: PR-12AC-R **AC**

Model: PR-12DC-DA-R **DC**

Model: PR-12DC-DA-TN **DC**

Specifications

Item	PR-12AC-R-E	PR-12DC-DA-R-E	PR-12AC-R	PR-12DC-DA-R	PR-12DC-DA-TN
Memory	64 Functional Blocks		512 Functional Blocks / 5K Steps		
Data Retentivity	-		10 years		
Program Backup	10 years				
RTC	Backup at 25 °C: 20 days, RTC accuracy : MAX ±2S/day				
Cycle time	0.6ms - 8.0ms				
Expansion	-				
Communication	1 Program/RS232 port Modbus RTU/ASCII only can serve as slaves		1 Program/RS232 port Modbus RTU/ASCII Can work either as slave or as master in Modbus network.		
Certificate					
Operation Temp	-20 °C .. +55 °C				
Storage Temp	-40 °C .. +70 °C				
Protection	IP20				
Dimensions	72*90*61 (Unit, mm) 4DIN				
Installation	35mm-DIN rail or screw for installation				
Weight	Approx. 300g				

I/O circuit diagrams

[Digital Input - Power AC]

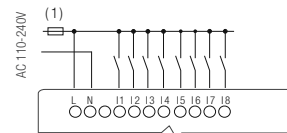

[Digital Input - Power DC]

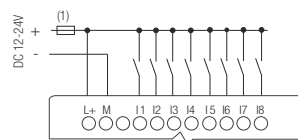

[DC analog inputs 0-10V - Power DC]

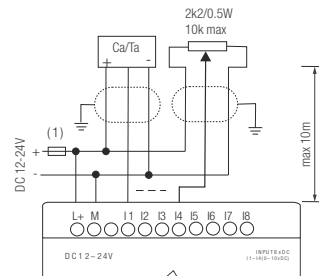

[Relay Outputs]

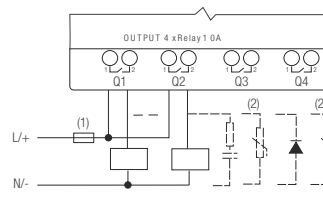

[Transistor Outputs PNP]

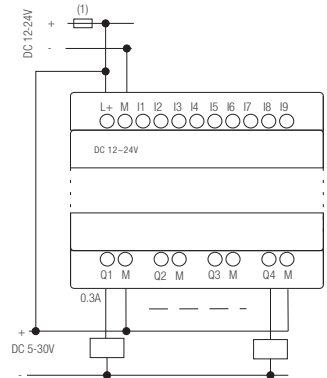

(1) - Fuse, circuit-breaker or circuit protector
(2) - Inductive load;

Item	PR-12AC-R-E	PR-12AC-R	PR-12DC-DA-R-E	PR-12DC-DA-R	PR-12DC-DA-TN
Nominal voltage	AC 110V-240V		DC 12-24V		
Operating limits	AC 85 - 265V		DC 10.8-28.8V		
The main frequency range	47-63Hz		-		
Immunity from micro power	-		Typ 5 ms		
Max startup current	-		Max 0.25A		Max 0.1A
Isolation voltage	1780V AC		-		
Max absorbed power	38 mA (85V AC) 30 mA (265V AC)	48.5 mA (85V AC) 35 mA (265V AC)	3.2 W (10.8V DC) 3.8 W (28.8V DC)	3.5 W (10.8V DC) 4 W (28.8V DC)	2 W (10.8V DC) 2.3 W (28.8V DC)
Protection against polarity inversions	Yes				
Input No	8 (I1-I8)				
Digital input	8 (I1-I8)				
Analogue input	-		4 (I1-I4) (0..10V DC)		
Input voltage	AC 110-240V		DC 0-28.8V		
Input signal 0	AC 0-40V <0.03mA		(I1-I4) <0.1mA / (I5-I8) <1mA @ < 5V DC		
Input signal 1	AC 79-240V >0.06mA		(I1-I4) >0.3mA / (I5-I8) >1.7mA @ > 8V DC		
Input current	-		(I1-I4) 0.4mA / (I5-I8) 2.3mA @ 10.8V DC (I1-I4) 0.5mA / (I5-I8) 2.6mA @ 12.0V DC (I1-I4) 1.2mA / (I5-I8) 5.2mA @ 24V DC (I1-I4) 1.5mA / (I5-I8) 6.3mA @ 28.8V DC		
Response time	0 to 1 : 120V AC : Typ. 50 ms 240V AC : Typ. 30 ms 1 to 0 : 120V AC : Typ. 90 ms 240V AC : Typ. 100 ms		(I1-I4): 0 to 1 : Typ. 1.5 ms 1 to 0 : Typ. 1.5 ms (I5-I8): 0 to 1 : Typ. <1 ms 1 to 0 : Typ. <1 ms		
Maximum counting frequency	Typ: 4 Hz		I1-I4: 4 Hz I5-I8: 60 kHz		
Sensor type	Contact or 3-wire PNP				
Input type	-		Resistive		
Isolation between power supply and inputs	-				
Isolation between inputs	-				
Protection against polarity inversions	Yes		-		
Measurement range	-		DC 0-10V		
Input impedance	-		Min 24KΩ Max 72KΩ		
Input voltage	-		28.8 V DC max		
Resolution	-		9bit 0.015V		10bit 0.01V
Accuracy at 25 °C	-		± (Max 0.03)V		± (Max 0.02)V
Accuracy at 55 °C	-		± (Max 0.06)V		± (Max 0.04)V
Isolation between analog inputs and power supply	-				
Cable length	-		10 m max shielded & twisted		

Specifications

Item	PR-12AC-R-E	PR-12DC-DA-R-E	PR-12AC-R	PR-12DC-DA-R	PR-12DC-DA-R-TN
Output No	4 (Q1-Q4)				
Output type	Relay output			Transistor (PNP)	
Continuous current	Resistive load 10A/Inductive load 2A			Max. 0.3 A per channel	
Max breaking voltage	AC 250 V DC 110 V			DC 5-30V	
Max breaking current	10A			0.65A	
Voltage drop	-			< 2 V for I = 0.3 A (at state 1)	
Galvanic isolation	Yes			-	
Max allowable power force	1250VA 300W			-	
Electrical durability expectancy	105 Operations at Rated Resistive Load			-	
Mechanical life	107 Operations at No Load condition			-	
Built-in protections	Against short-circuits: None Against overvoltages and overloads: None				
Response time	Operate Time : 15 ms max. Release Time : 10 ms max.			Make ≤ 1 ms Release ≤ 1 ms	
Mechanism	10Hz			-	
Resistor/light load	2Hz			10Hz	
Sensitive load	0.5Hz			-	
PWM frequency	-			10kHz	
PWM accuracy at 120Hz	-			< 0.5 % (20 % - 80 %) load at 10 mA	
PWM accuracy at 500Hz	-			< 0.5% (20 % - 80 %) load at 10 mA	
Max. Breaking current PWM	-			50mA	
Max. cable length PWM	-			20m	
PWM cyclic ratio	-			0 to 100 %	

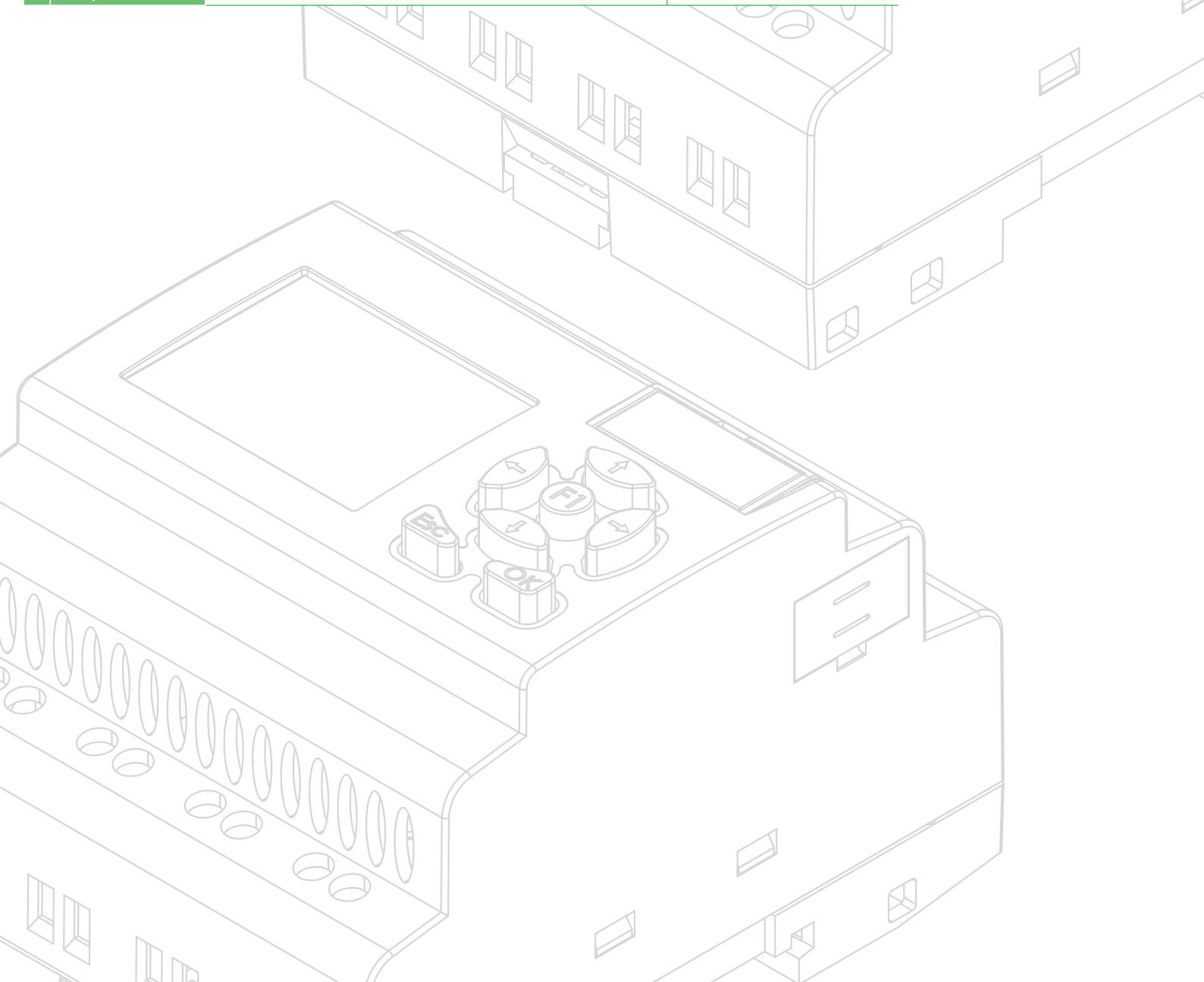

14 I/O Expandable



PR-14

Model: PR-14AC-R **AC**

Model: PR-14DC-DA-R **DC**

Specifications

Item	PR-14AC-R	PR-14DC-DA-R
Nominal voltage	AC 110V-240V	DC 12-24V
Operating limits	AC 85 - 265V	DC 10.8-28.8V
The main frequency range	47-63Hz	-
Immunity from micro power	-	Typ 5 ms
Max startup current	-	Max 0.25A
Isolation voltage	1780V AC	-
Max absorbed power	49 mA (85V AC) 37 mA (265V AC)	3.5 W (10.8V DC) 4W (28.8V DC)
Protection against polarity inversions	Yes	
Input No	10 (I1-IA)	
Digital input	10 (I1-IA)	
Analogue input	-	6 (I1-I6) (0..10V DC)
Input voltage	AC 110-240V	DC 0-28.8V
Input signal 0	AC 0-40V <0.03mA	(I1-I6) <0.1mA / (I7-IA) <1mA @ < 5V DC
Input signal 1	AC 79-240V >0.06mA	(I1-I6) >0.3mA / (I7-IA) >1.7mA @ > 8V DC
Input current	-	(I1-I6) 0.4mA / (I7-IA) 2.3mA @ 10.8V DC (I1-I6) 0.5mA / (I7-IA) 2.6mA @ 12.0 V DC (I1-I6) 1.2mA / (I7-IA) 5.2mA @ 24 V DC (I1-I6) 1.5mA / (I7-IA) 6.3mA @ 28.8 V DC
Response time	0 to 1: 120V AC : Typ. 50 ms 240V AC : Typ. 30 ms 1 to 0: 120V AC : Typ. 90 ms 240V AC : Typ.100 ms	(I1-I6): 0 to 1: Typ. 1.5 ms 1 to 0: Typ. 1.5 ms (I7-IA): 0 to 1: Typ. <1 ms 1 to 0: Typ. <1 ms
Maximum counting frequency	Typ: 4 Hz	I1-I6: 4 Hz I7-IA: 60 kHz
Sensor type	Contact or 3-wire PNP	
Input type	-	Resistive
Isolation between power supply and inputs	-	
Isolation between inputs	-	
Protection against polarity inversions	Yes	-
Measurement range	-	DC 0-10V
Input impedance	-	Min 24KΩ Max 72KΩ
Input voltage	-	28.8 V DC max
Resolution	-	10bit 0.01V
Accuracy at 25 °C	-	± (Max 0.02)V
Accuracy at 55 °C	-	± (Max 0.04)V
Isolation between analog inputs and power supply	-	
Cable length	-	10 m max shielded & twisted

Item	PR-14
Memory	512 Functional Blocks / 5K Steps
Data Retentivity	10 years
Program Backup	10 years
RTC	Backup at 25 °C: 20 days, RTC accuracy : MAX ±2S/day
Cycle time	0.6ms - 8.0ms
Expansion	16 modules (PR-E-16)
Communication	1 RS232 port & 2 RS485 port (1 built-in) Modbus RTU/ASCII Master or Slave
Certificate	
Operation Temp	-20 °C .. +55 °C
Storage Temp	-40 °C .. +70 °C
Protection	IP20
Dimensions	95*90*55 (Unit, mm) 6DIN
Installation	35mm-DIN rail or screw for installation
Weight	Approx. 400g

Item	PR-14AC-R	PR-14DC-DA-R
Output No	4 (Q1-Q4)	
Output type	Relay output	
Continuous current	Resistive load 10A/Inductive load 2A	
Max breaking voltage	AC 250 V DC 110 V	
Max allowable power force	1250VA 300W	
Electrical durability expectancy	105 Operations at Rated Resistive Load	
Mechanical life	107 Operations at No Load condition	
Built-in protections	Against short-circuits: None Against overvoltages and overloads: None	
Response time	Operate Time : 15 ms max Release Time : 10 ms max	
Mechanism	10Hz	
Resistor/light load	2Hz	
Sensitive load	0.5Hz	

I/O circuit diagrams

[Digital Input - Power AC]

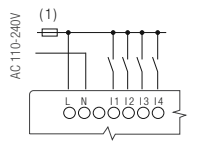

[DC analog inputs 0-10V - Power DC]

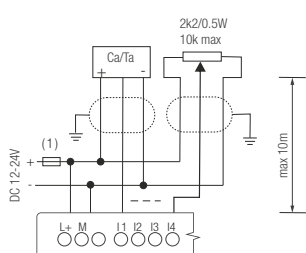

[Relay Outputs]

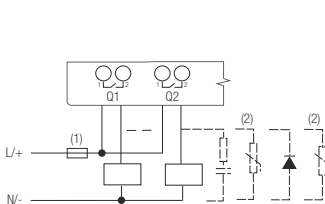

[RS485 Connection]

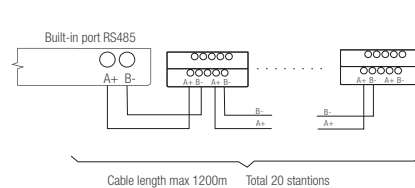

(1) - Fuse, circuit-breaker or circuit protector
(2) - Inductive load;

18

I/O
Expandable



PR-18

- Model: PR-18AC-R AC
- Model: PR-18DC-DA-R DC
- Model: PR-18DC-DA-RT DC

Specifications

Item	PR-18AC-R	PR-18DC-DA-R	PR-18DC-DA-RT
Nominal voltage	AC 110V-240V	DC 12-24V	
Operating limits	AC 85 - 265V	DC 10.8-28.8V	
The main frequency range	47-63Hz	-	
Immunity from micro power	-	Typ 5 ms	
Max startup current	-	Max 0.25A	
Isolation voltage	1780V AC	-	
Max absorbed power	49 mA (85V AC) 37 mA (265V AC)	3.5 W (10.8V DC) 4W (28.8V DC)	
Protection against polarity inversions	Yes		
Input No	-	12 (I1-IC)	
Digital input	-	12 (I1-IC)	
Analogue input	-	6 (I1-I6) (0..10V DC)	
Input voltage	AC 110-240V	DC 0-28.8V	
Input signal 0	AC 0-40V <0.03mA	(I1-I6) <0.1mA / (I7-IC) <1mA @ < 5V DC	
Input signal 1	AC 79-240V >0.06mA	(I1-I6) >0.3mA / (I7-IC) >1.7mA @ > 8V DC	
Input current	-	(I1-I6) 0.4mA / (I7-IC) 2.3mA @ 10.8V DC (I1-I6) 0.5mA / (I7-IC) 2.6mA @ 12.0 V DC (I1-I6) 1.2mA / (I7-IC) 5.2mA @ 24 V DC (I1-I6) 1.5mA / (I7-IC) 6.3mA @ 28.8 V DC	
Response time	0 to 1: 120V AC : Typ. 50 ms 240V AC : Typ. 30 ms 1 to 0: 120V AC : Typ. 90 ms 240V AC : Typ.100 ms	(I1-I6): 0 to 1: Typ. 1.5 ms 1 to 0: Typ. 1.5 ms (I7-IC): 0 to 1: Typ. <1 ms 1 to 0: Typ. <1 ms	
Maximum counting frequency	Typ: 4 Hz	I1-I8: 4 Hz I9-IC: 60 kHz	
Sensor type	Contact or 3-wire PNP		
Input type	-	Resistive	
Isolation between power supply and inputs	-		
Isolation between inputs	-		
Protection against polarity inversions	Yes	-	
Measurement range	-	DC 0-10V	
Input impedance	-	Min 24KΩ Max 72KΩ	
Input voltage	-	28.8 V DC max	
Resolution	-	10bit 0.01V	
Accuracy at 25 °C	-	± (Max 0.02)V	
Accuracy at 55 °C	-	± (Max 0.04)V	
Isolation between analog inputs and power supply	-		
Cable length	-	10 m max shielded & twisted	

Item	PR-18
Memory	1024 Functional Blocks / 13K Steps
Data Retentivity	10 years
Program Backup	10 years
RTC	Backup at 25 °C: 20 days, RTC accuracy : MAX ±2S/day
Cycle time	0.6ms - 8.0ms
Expansion	16 modules (PR-E-16)
Communication	1 RS232 port & 1 RS485 port (PR-E-RS485) Modbus RTU/ASCII Master or Slave
Certificate	
Operation Temp	-20 °C .. +55 °C
Storage Temp	-40 °C .. +70 °C
Protection	IP20
Dimensions	95*90*55 (Unit, mm) 6DIN
Installation	35mm-DIN rail or screw for installation
Weight	Approx. 400g

I/O circuit diagrams

[Digital Input - Power AC]

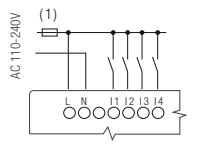

[DC analog inputs 0-10V - Power DC]

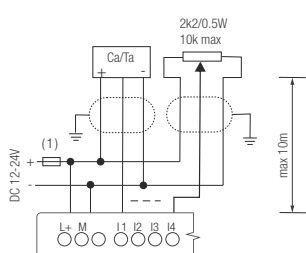

[Relay Outputs]

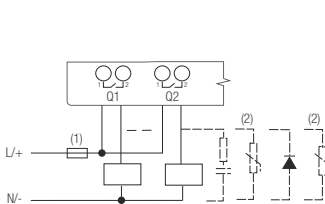

[Transistor Outputs PNP]

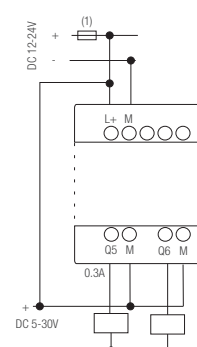

(1) - Fuse, circuit-breaker or circuit protector
(2) - Inductive load,

Specifications

Item	PR-18AC-R	PR-18DC-DA-R	PR-18DC-DA-RT	
			Relay	Transistor
Output No	6 (Q1-Q6)			
Output type	Relay output		4 (Q1-Q4) Relay output 2 (Q5-Q6) Transistor output	
Continuous current	Resistive load 10A/Inductive load 2A		Max. 0.3 A per channel	
Max breaking voltage	AC 250 V DC 110 V		DC 5-30V	
Max breaking current	10A		0.65A	
Voltage drop	-		< 2 V for I = 0.3 A (at state 1)	
Galvanic isolation	Yes		-	
Max allowable power force	1250VA 300W		-	
Electrical durability expectancy	105 Operations at Rated Resistive Load		-	
Mechanical life	107 Operations at No Load condition		-	
Built-in protections	Against short-circuits: None Against overvoltages and overloads: None			
Response time	Operate Time : 15 ms max Release Time : 10 ms max		Make ≤ 1 ms Release ≤ 1 ms	
Mechanism	10Hz		-	
Resistor/light load	2Hz		10Hz	
Sensitive load	0.5Hz			
PWM frequency	-		10kHz Q5, Q6 must have same frequency when PWM works	
PWM accuracy at 120Hz	-		< 0.5 % (20 % - 80 %) load at 10 mA	
PWM accuracy at 500Hz	-		< 0.5% (20 % - 80 %) load at 10 mA	
Max. Breaking current PWM	-		50mA	
Max. cable length PWM	-		20m	
PWM cyclic ratio	-		0 to 100 %	

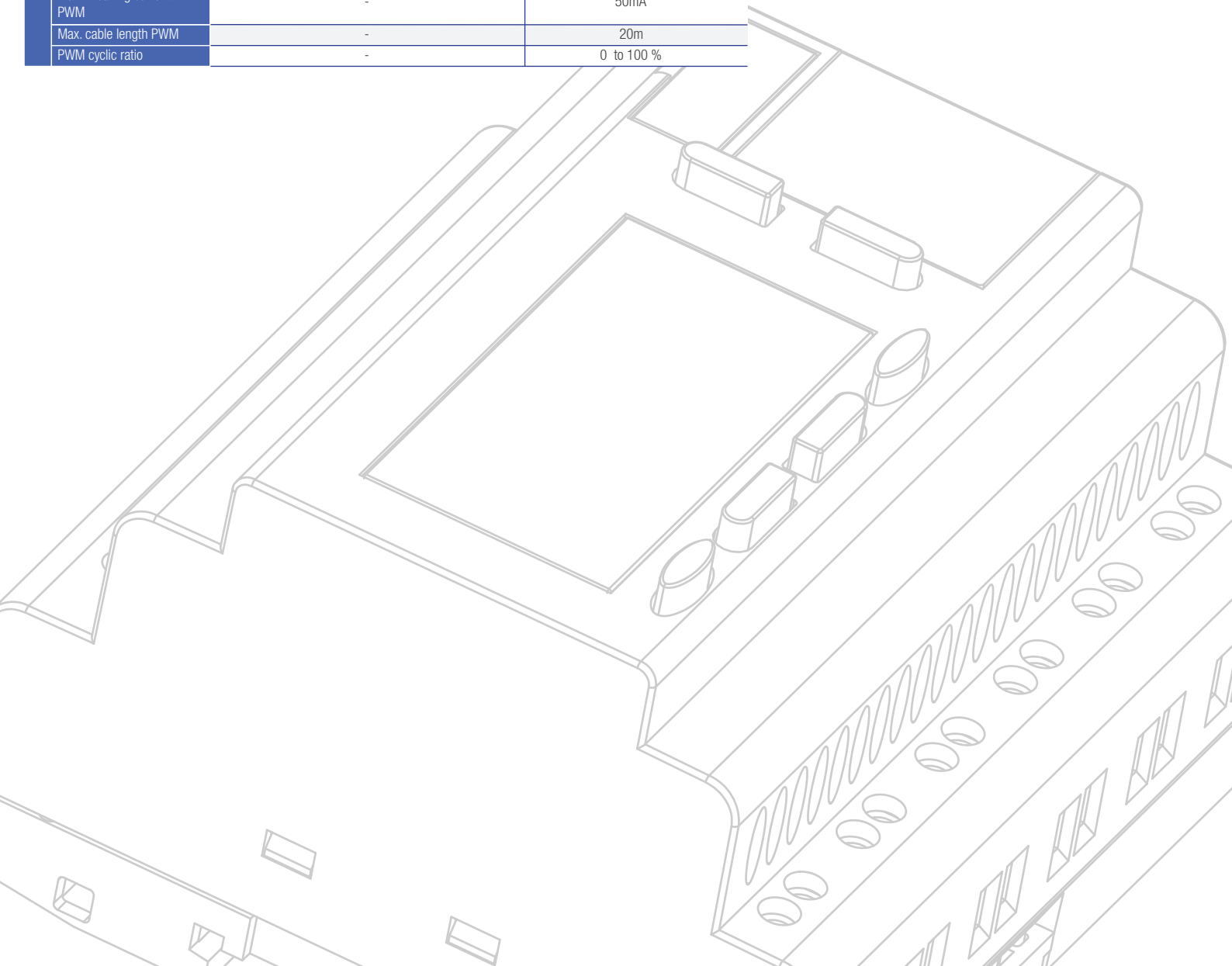

24
I/O
Expandable

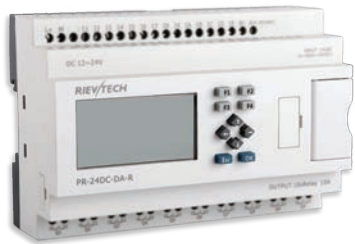

PR-24

Model: PR-24AC-R **AC**

Model: PR-24DC-DA-R **DC**

Model: PR-24DC-DAI-RTA **DC**

Specifications

Item	PR-24AC-R	PR-24DC-DA-R	PR-24DC-DAI-RTA
Nominal voltage	AC 110V-240V	DC 12-24V	
Operating limits	AC 85 - 265V	DC 10.8-28.8V	
The main frequency range	47-63Hz	-	
Immunity from micro power	-	Typ 5 ms	
Max startup current	-	Max 0.25A	
Isolation voltage	1780V AC	-	
Max absorbed power	49 mA (85V AC) 37 mA (265V AC)	3.5 W (10.8V DC) 4W (28.8V DC)	
Protection against polarity inversions	Yes		
Input No	14 (I1-IE)		
Digital input	14 (I1-IE)		12 (I1-I4)(I7-IE)
Analogue input	-	6 (I1-I6) (0..10V DC)	4 (I1-I4) (0..10V DC) 2 (I5-I6) (0..20mA)
Input voltage	AC 110-240V	DC 0-28.8V	
Input signal 0	AC 0-40V <0.03mA	(I1-I4) <0.1mA / (I7-IE) <1mA @ < 5V DC	
Input signal 1	AC 79-240V >0.06mA	(I1-I4) >0.3mA / (I7-IE) >1.7mA @ > 8V DC	
Input current	-	(I1-I4) 0.4mA / (I7-IE) 2.3mA @ 10.8V DC (I1-I4) 0.5mA / (I7-IE) 2.6mA @ 12.0 V DC (I1-I4) 1.2mA / (I7-IE) 5.2mA @ 24 V DC (I1-I4) 1.5mA / (I7-IE) 6.3mA @ 28.8 V DC	
Response time	0 to 1: 120V AC : Typ. 50 ms 240V AC : Typ. 30 ms 1 to 0: 120V AC : Typ. 90 ms 240V AC : Typ. 100 ms	(I1-I6): 0 to 1: Typ. 1.5 ms 1 to 0: Typ. 1.5 ms (I7-IE): 0 to 1: Typ. <1 ms 1 to 0: Typ. <1 ms	
Maximum counting frequency	Typ: 4 Hz	I1-I4, I7-I8, I9-IE: 4 Hz I9-IC: 60 kHz	
Sensor type	Contact or 3-wire PNP		
Input type	-	Resistive	
Isolation between power supply and inputs	-		
Isolation between inputs	-		
Protection against polarity inversions	Yes	-	
Measurement range	-	DC 0-10V	
Input impedance	-	Min 24KΩ Max 72KΩ	
Input voltage	-	28.8 V DC max	
Resolution	-	10bit 0.01V	
Accuracy at 25 °C	-	± (Max 0.02)V	
Accuracy at 55 °C	-	± (Max 0.04)V	
Isolation between analog inputs and power supply	-		
Cable length	-	10 m max shielded & twisted	
Current input No	-	2 (I5-I6)	
Analogue signal	-	0/4...20mA current	
Resolution	-	0.02mA	
Accuracy at 25 °C	-	0.05mA	
Cycle time for analog value generation	-	Typ. 50 ms	

Item	PR-24
Memory	1024 Functional Blocks / 13K Steps
Data Retentivity	10 years
Program Backup	10 years
RTC	Backup at 25 °C: 20 days, RTC accuracy : MAX ±2S/day
Cycle time	0.6ms - 8.0ms
Expansion	16 modules (PR-E-16)
Communication	1 RS232 port & 2 RS485 port (1 Built-in) Modbus RTU/ASCII Master or Slave
Certificate	
Operation Temp	-20 °C .. +55 °C
Storage Temp	-40 °C .. +70 °C
Protection	IP20
Dimensions	133*90*55 (Unit, mm) 10DIN
Installation	35mm-DIN rail or screw for installation
Weight	Approx. 500g

Circuit diagrams

[Digital Input - Power AC]

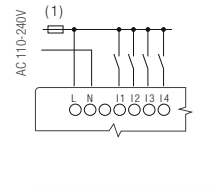

[Digital Input - Power DC]

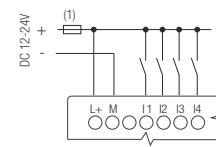

[Transistor Outputs PNP]

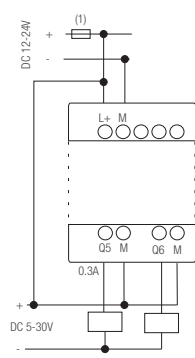

[DC analog inputs 0-10V - Power DC]

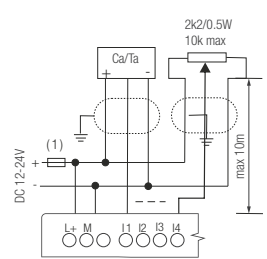

[DC analog inputs 0-20mA - Power DC]

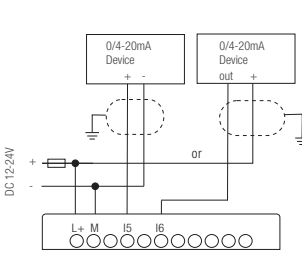

[Relay Outputs]

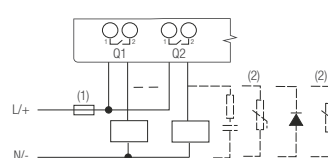

(1) - Fuse, circuit-breaker or circuit protector
(2) - Inductive load;

Circuit diagrams

[RS485 Connection]

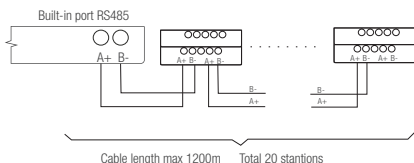

[DC Analog Outputs - 0-10V / 0-20mA]

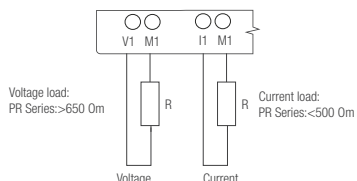

Specifications

Item	PR-24AC-R	PR-24DC-DA-R	PR-24DC-DAI-RTA	
			Relay	Transistor
Output No	10 (Q1-QA)		9 (Q1-Q8, AQ9)	
Output type	Relay output		6 (Q1-Q6) Relay output 2 (Q7-Q8) Transistor PNP output 1 (AQ9) Analog output (0-10/0-20mA)	
Continuous current	Resistive load 10A/Inductive load 2A		Max. 0.3 A per channel	
Max breaking voltage	AC 250 V DC 110 V		DC 5-30V	
Max breaking current	10A		0.65A	
Voltage drop	-		< 2 V for I = 0.3 A (at state 1)	
Galvanic isolation	Yes		-	
Max allowable power force	1250VA 300W		-	
Electrical durability expectancy	105 Operations at Rated Resistive Load		-	
Mechanical life	107 Operations at No Load condition		-	
Built-in protections	Against short-circuits: None Against overvoltages and overloads: None			
Response time	Operate Time : 15 ms max Release Time : 10 ms max		Make ≤ 1 ms Release ≤ 1 ms	
Mechanism	10Hz		-	
Resistor/light load	2Hz		10Hz	
Sensitive load	0.5Hz			
PWM frequency	-		10kHz Q7, Q8 must have same frequency when PWM works	
PWM accuracy at 120Hz	-		< 0.5 % (20 % - 80 %) load at 10 mA	
PWM accuracy at 500Hz	-		< 0.5% (20 % - 80 %) load at 10 mA	
Max. Breaking current PWM	-		50mA	
Max. cable length PWM	-		20m	
PWM cyclic ratio	-		0 to 100 %	
Output signal	-		DC 0...10V	
Internal value and signal relationship	-		AQ9 (0..1000) = V1(0...10V)	
Resolution	-		0.01V	
Accuracy at 25 °C	-		0.02V	
Output signal	-		0..20mA	
Internal value and signal relationship	-		AQ9 (0..1000) = I1(0...20mA)	
Resolution	-		0.02mA	
Accuracy at 25 °C	-		0.05mA	

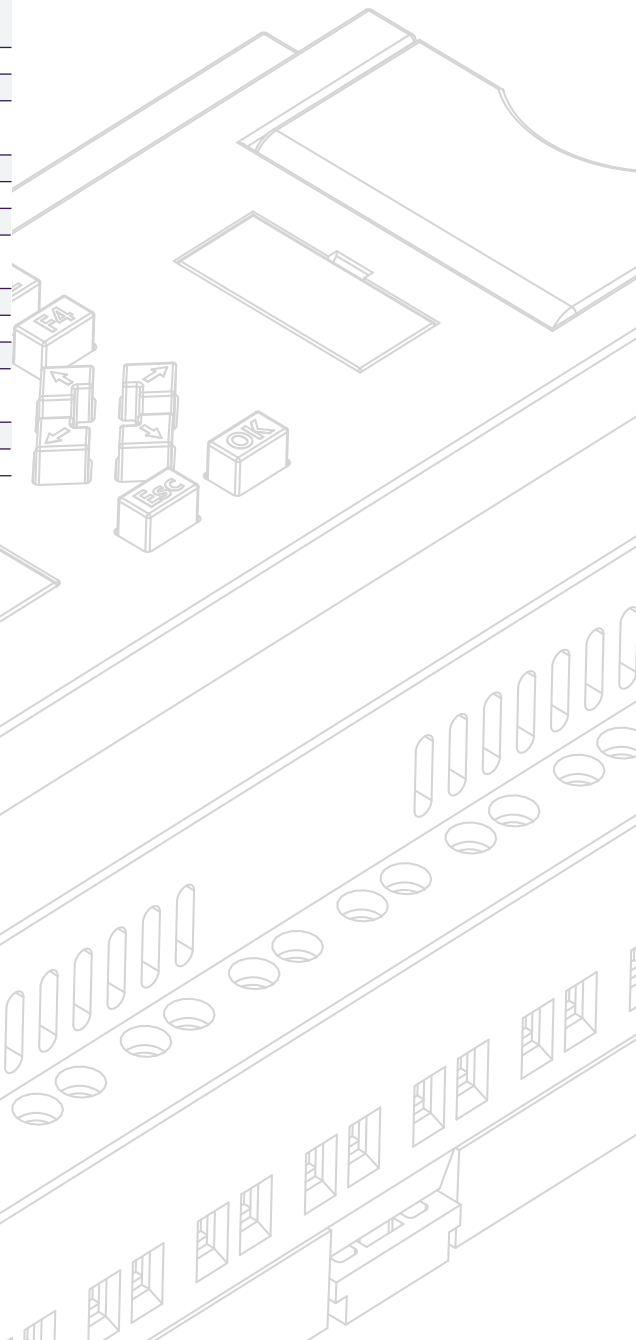

Extension Modules



PR-E

Model: PR-E-16AC-R **AC**

Model: PR-E-16DC-DA-R **DC**

Model: PR-E-16DC-DA-TN **DC**

Model: PR-E-AI-I **DC**

Model: PR-E-PT100 **DC**

Model: PR-E-AQ-VI **DC**

Model: PR-E-RS485 **DC**

Specifications

Item	PR-E-16AC-R	PR-E-16DC-DA-R	PR-E-16DC-DA-TN
Nominal voltage	AC 110V-240V	DC 12-24V	
Operating limits	AC 85 - 265V	DC 10.8-28.8V	
The main frequency range	47-63Hz	-	
Immunity from micro power	-	Typ 5 ms	
Max startup current	-	Max 0.25A	
Isolation voltage	1780V AC	-	
Max absorbed power	53 mA (85V AC) 38 mA (265V AC)	3.5 W (10.8V DC) 4.5W (28.8V DC)	
Protection against polarity inversions	Yes		
Input No	8 (I1-I8)		
Digital input	8 (I1-I8)		
Analogue input	-	4 (I1-I4) (0..10V DC)	
Input voltage	AC 110-240V	DC 0-28.8V	
Input signal 0	AC 0-40V <0.03mA	(I1-I4) <0.1mA / (I5-I8) <1mA @ < 5V DC	
Input signal 1	AC 79-240V >0.06mA	(I1-I4) >0.3mA / (I5-I8) >1.7mA @ > 8V DC	
Input current	-	(I1-I4) 0.4mA / (I5-I8) 2.3mA @ 10.8V DC (I1-I4) 0.5mA / (I5-I8) 2.6mA @ 12.0 V DC (I1-I4) 1.2mA / (I5-I8) 5.2mA @ 24 V DC (I1-I4) 1.5mA / (I5-I8) 6.3mA @ 28.8 V DC	
Response time	0 to 1: 120V AC : Typ. 50 ms 240V AC : Typ. 30 ms 1 to 0: 120V AC : Typ. 90 ms 240V AC : Typ. 100 ms	(I1-I4): 0 to 1: Typ. 1.5 ms 1 to 0: Typ. 1.5 ms (I5-I8): 0 to 1: Typ. <1 ms 1 to 0: Typ. <1 ms	
Maximum counting frequency	Typ: 4 Hz	4 Hz	
Sensor type	Contact or 3-wire PNP		
Input type	-	Resistive	
Isolation between power supply and inputs	-		
Isolation between inputs	-		
Protection against polarity inversions	Yes	-	
Measurement range	-	DC 0-10V	
Input impedance	-	Min 24KΩ Max 72KΩ	
Input voltage	-	28.8 V DC max	
Resolution	-	9bit 0.015V	
Accuracy at 25 °C	-	± (Max 0.03)V	
Accuracy at 55 °C	-	± (Max 0.06)V	
Isolation between analog inputs and power supply	-		
Cable length	-	10 m max shielded & twisted	

Item	PR-E-RS485
Nominal voltage	DC 12-24V
Operating limits	DC 10.8-28.8V
Immunity from micro power	Typ 5 ms
Max. Startup current	Max. 0.1A
Max absorbed power	1.5 W (10.8V DC) 1.8W W (28.8V DC)
Protection against polarity inversions	Yes

Item	PR-E
Compatibility	PR-14, PR-18, PR-24
Certificate	
Operation Temp	-20 °C .. +55 °C
Storage Temp	-40 °C .. +70 °C
Protection	IP20
Dimensions	72*90*61 (Unit, mm) 4DIN
Installation	35mm-DIN rail or screw for installation
Weight	Approx. 300g

Item	PR-E-AI-I	PR-E-PT100	PR-E-AQ-VI
Nominal voltage	DC 12-24V		
Operating limits	DC 10.8-28.8V		
Immunity from micro power	Typ 5 ms		
Max. Startup current	Max. 0.25A		
Max absorbed power	1W	1.8W	
Protection against polarity inversions	Yes		
Input No	4 (I1-I4)	3 (I1-I3)	-
Digital input	-		
Analogue input	4 (AI1-AI4)	3 (AI1-AI3)	-
Analogue signal	0/4...20mA current	RTD PT100	-
Resolution	0.02mA 10bit	0.3°C 10bit	-
Measuring range	-	-50°C to +200°C	-
Accuracy at 25 °C	0.05mA	-	-
Output No	-	-	2(AQ1-AQ2)
Output signal	-	-	DC 0...10V or 0..20mA
Internal value and signal relationship	-	-	AQ1/2 (0..1000)= V1(0...10V)= I1(0...20mA)
Resolution	-	-	0.01V or 0.02mA 10bit
Accuracy at 25 °C	-	-	0.02V or 0.05mA
Cycle time for analog value generation	Typ. 50 ms		
Cable length	10 m max shielded & twisted		

Specifications

Item	PR-E-16AC-R	PR-E-16DC-DA-R	PR-E-16DC-DA-TN
Output No	8 (Q1-Q8)		
Output type	Relay output		Transistor PNP output
Continuous current	Q1-Q4: Resistive load 3A/Inductive load 1A Q5-Q8: Resistive load 10A/Inductive load 2A		Max. 0.3 A per channel
Max breaking voltage	AC 250 V DC 110 V		DC 5-30V
Max breaking current	10A		0.65A
Voltage drop	-		< 2 V for I=0.3 A (at state 1)
Galvanic isolation	Yes		-
Max allowable power force	(Q1-Q4) 500VA 100W (Q5-Q8) 1250VA 300W		-
Electrical durability expectancy	105 Operations at Rated Resistive Load		-
Mechanical life	107 Operations at No Load condition		-
Built-in protections	Against short-circuits: None Against overvoltages and overloads: None		
Response time	Operate Time : 15 ms max Release Time : 10 ms max		Make ≤ 70 ms Release ≤ 70 ms
Mechanism	10Hz		-
Resistor/light load	2Hz		10Hz
Sensitive load	0.5Hz		

Circuit diagrams

[DC analog inputs 0-10V - Power DC]

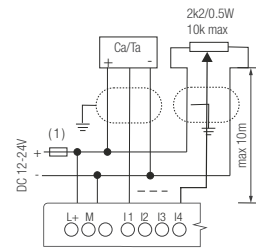

[DC analog inputs 0-20mA - Power DC]

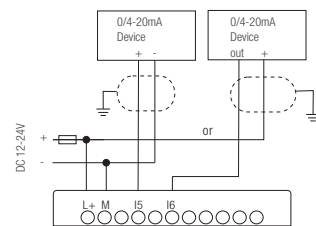

[RS485 Connection]

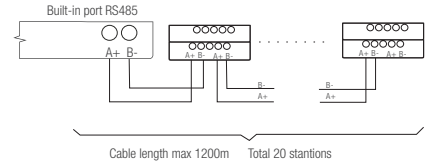

Circuit diagrams

[Digital Input - Power AC]

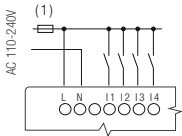

[Relay Outputs]

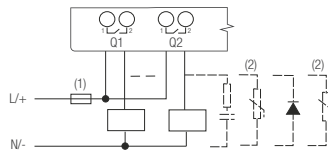

[Digital Input - Power DC]

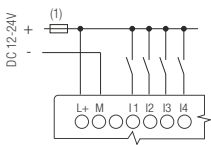

[Transistor Outputs PNP]

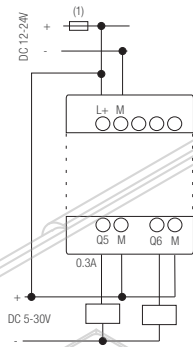

[DC Analog Outputs - 0-10V / 0-20mA]

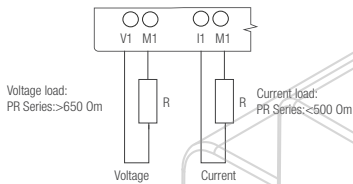

(1) - Fuse, circuit-breaker or circuit protector
(2) - Inductive load;

(1) - Fuse, circuit-breaker or circuit protector
(2) - Inductive load;

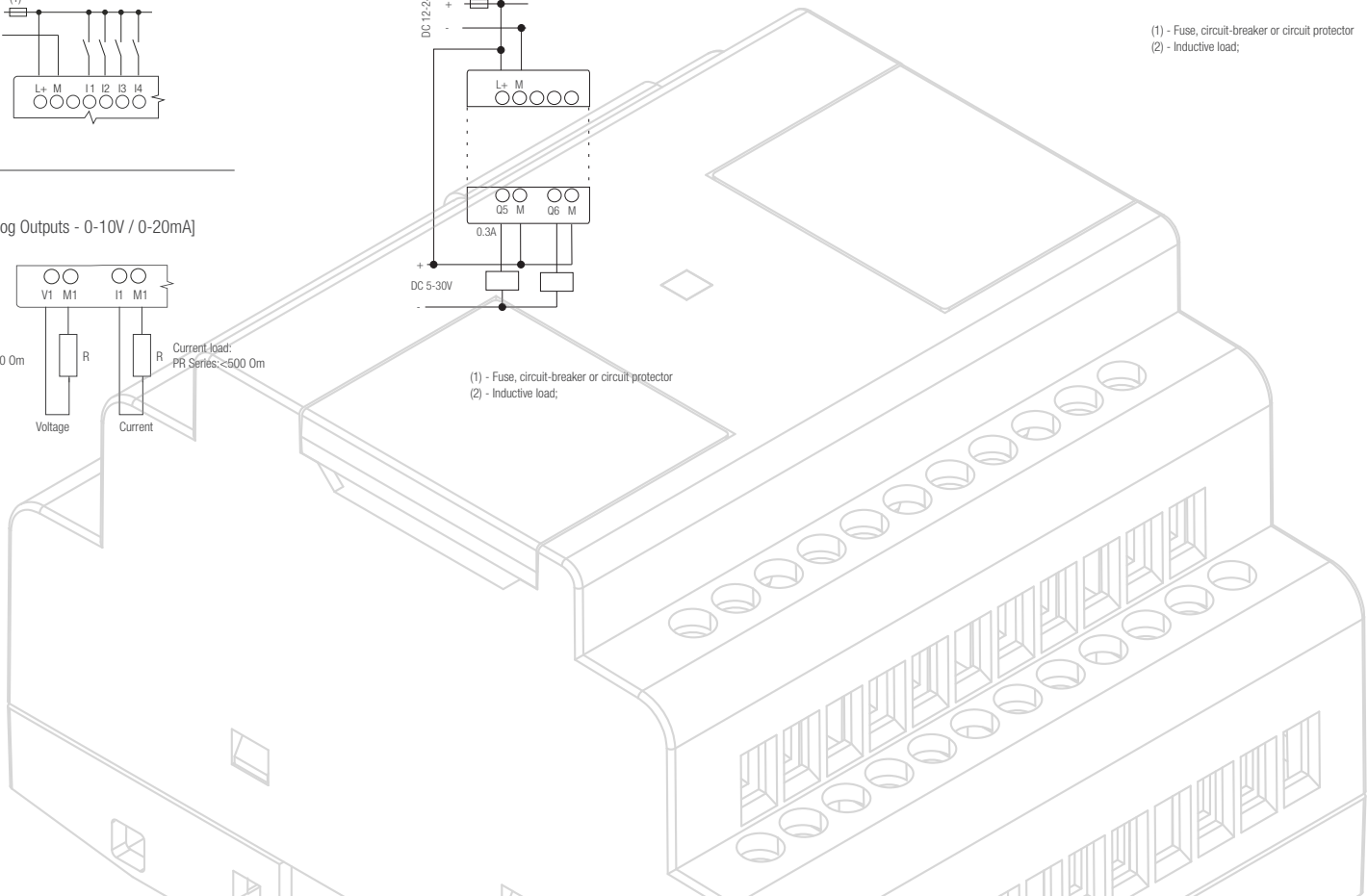

PR-6 Series

- PR-6AC-R
- PR-6DC-DA-R

(Unit: mm)

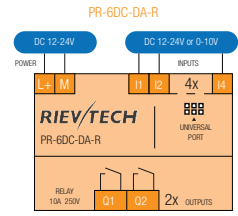
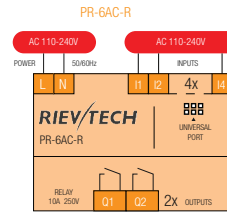
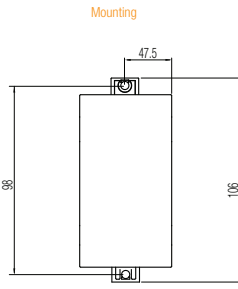
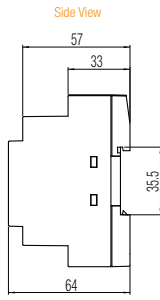
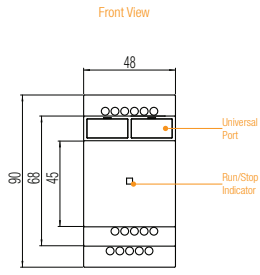

PR-12 Series

- PR-12AC-R-E
- PR-12DC-DA-R-E
- PR-12AC-R
- PR-12DC-DA-R
- PR-12DC-DA-TN

(Unit: mm)

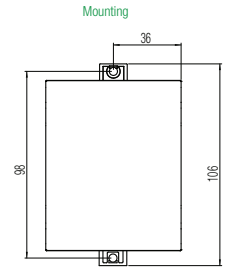
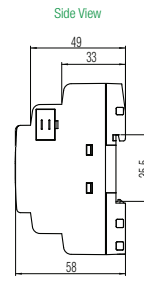
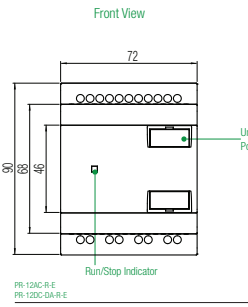
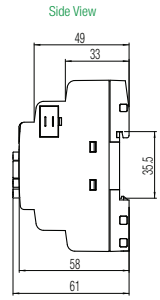
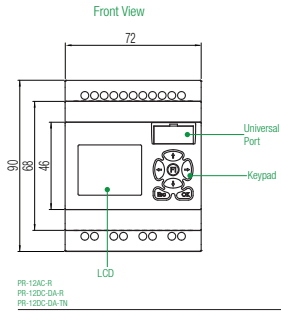

PR-12AC-R
PR-12DC-DA-R
PR-12DC-DA-TN

PR-12AC-R-E
PR-12DC-DA-R-E

PR-12AC-R-E / PR-12AC-R

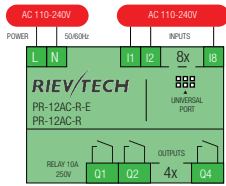

PR-12DC-DA-R-E / PR-12DC-DA-R

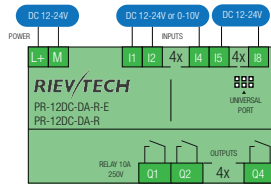

PR-12DC-DA-TN

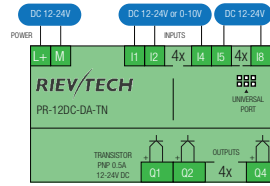

PR-14 Series

- PR-14AC-R
- PR-14DC-DA-R

(Unit: mm)

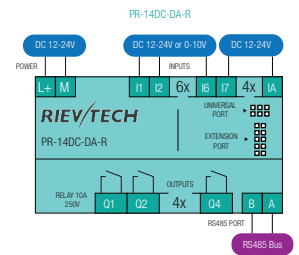
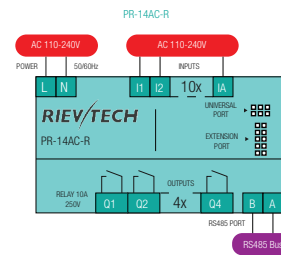
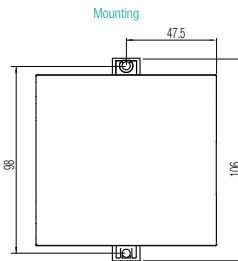
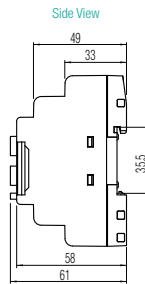
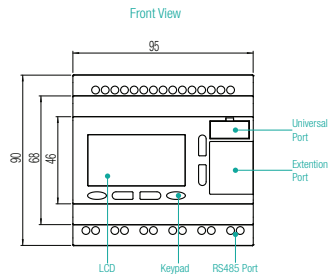

PR-18 Series

- PR-18AC-R
- PR-18DC-DA-R
- PR-18DC-DA-RT

(Unit: mm)

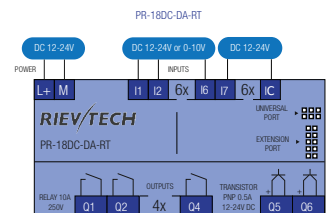
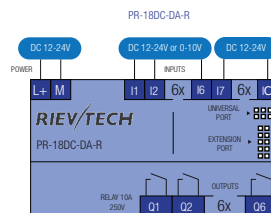
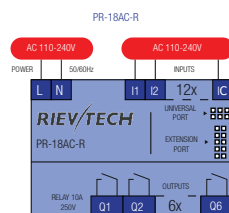
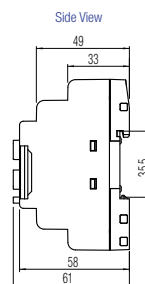
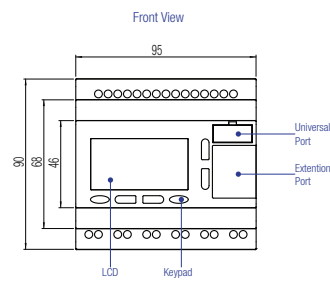

PR-24 Series

- PR-24AC-R
- PR-24DC-DA-R
- PR-24DC-DAI-RTA

(Unit: mm)

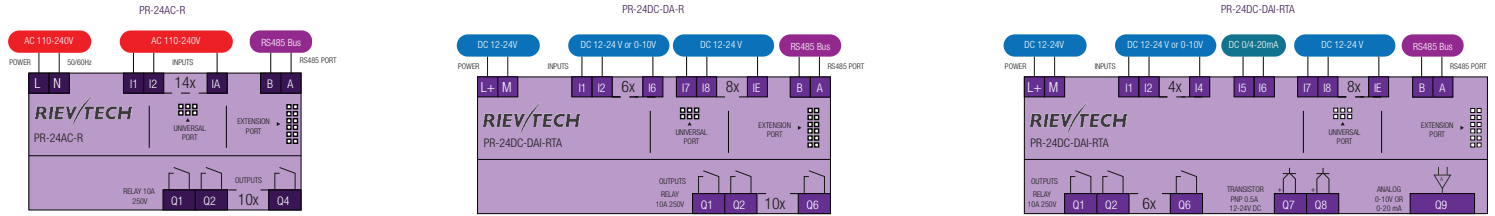
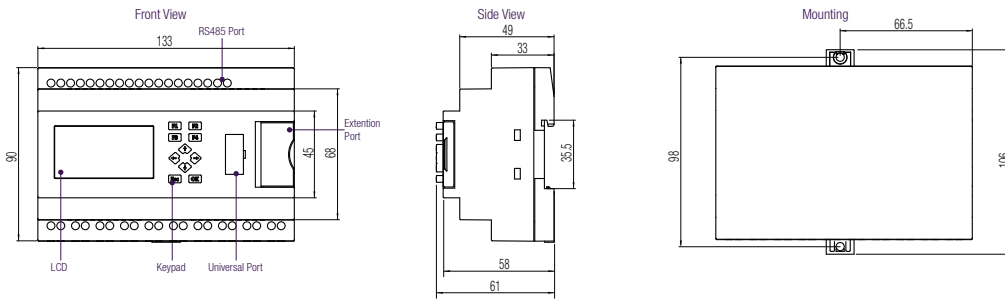

PR-E Expanction Modules

- PR-E-16AC-R
- PR-E-16DC-DA-R
- PR-E-16DC-DA-TN
- PR-E-AI-I
- PR-E-PT100
- PR-E-AQ-VI
- PR-E-RS485

(Unit: mm)

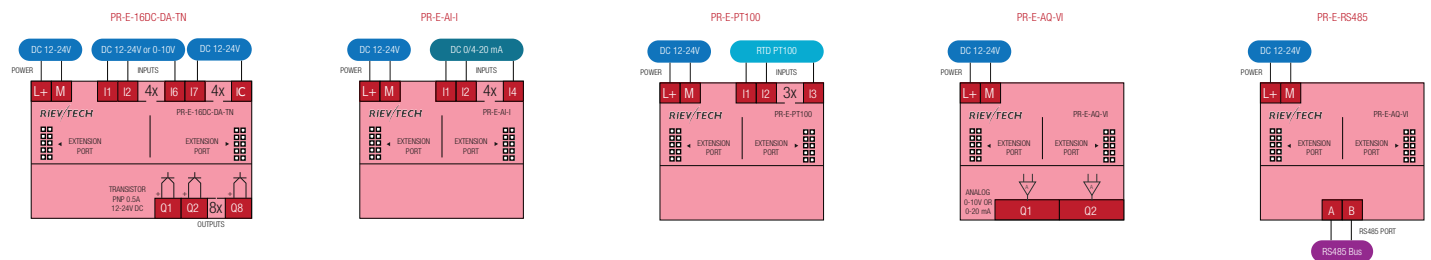
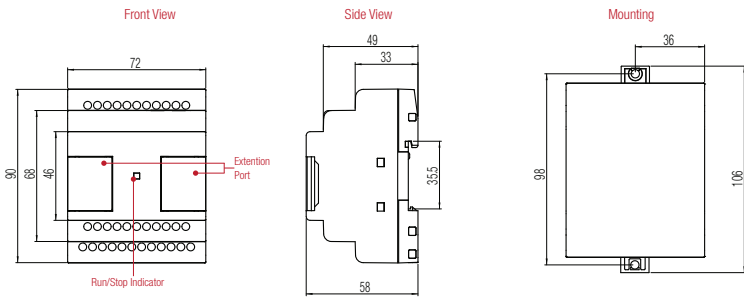

Optional Accessories

- RS232 Cable
- USB Cable
- PRO-RS485 Cable
- PR-Copier
- PR-Battery
- PR-Memory

(Unit: mm)

Cables

Model	Configuration	Compatibility
RS232 Cable	D-Sub connector (9-pin female) - PR-series peripheral connector Length: 2m	PR-6, PR-12, PR-14, PR-18, PR-24
USB Cable	USB type A plug connector (male) - PR-series peripheral connector Length: 2m	PR-6, PR-12, PR-14, PR-18, PR-24
PRO-RS485 Cable	Terminal block connector - PR-series peripheral connector Length: 2m	PR-6, PR-12, PR-14, PR-18, PR-24

Accessories

Model	Description	Dimensions	Compatibility
PR-Copier	PR-COPIER can be used to save user program and download program into CPUs.		PR-6, PR-12, PR-14, PR-18, PR-24
PR-Battery	Battery for RTC (backup 3 years)		PR-6, PR-12, PR-14, PR-18, PR-24
PR-Memory	For Data Logging on a microSD Card		PR-6, PR-12, PR-14, PR-18, PR-24

CPU Model

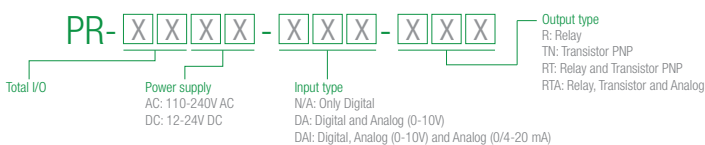

Analogs I/O and Communication Extension Module Model

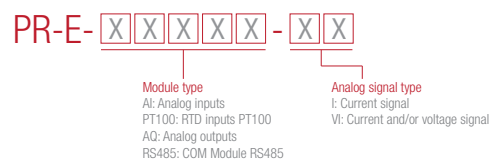

Combine I/O Extension Module Model

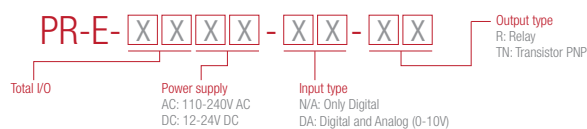



No. 88, Dazhou Road,
Yuhuatai Dist., Nanjing,
Jiangsu, China (Mainland)

Tel. +86-025-52895099
Tel. +86-025-52890128
Fax +86-025-52890128

info@rievtech.com - General
sales@rievtech.com - Commercial
tech@rievtech.com - Technical

www.rievtech.com