

Industrial Ethernet Switch

User's manual

OC-7N1000 series (100M unmanaged switch)

This manual refers to the following products. Features vary between types

Order code	Features	Availability
OC-7N1101	1x10/100Base-TX+1x10/100Base-FX SPF	Optional – contact for details
OC -7N1102	2x10/100Base-TX+1x10/100Base-FX SPF	Optional – contact for details
OC -7N1104	4x10/100Base-TX+1x10/100Base-FX SPF	Optional – contact for details
OC -7N1005	5x10/100Base-TX	Standard stock item
OC -7N1008	8x10/100Base-TX	Standard stock item
OC -7N1016	16x10/100Base-TX	Standard stock item
OC -7N1024	24x10/100Base-TX	Optional – contact for details

*Optical port supports 1*9 module optional, electrical port supports POE optional.

OPTICOMBINE

Product Introduction

OC-7N1000 series (100M unmanaged) industrial-grade Ethernet switch is an entry-level product specifically launched for the industrial control field. This product can provide stable and reliable Ethernet transmission, with high-quality design and reliability. It can provide users with high-efficiency bandwidth and reliable optical fiber network solutions for Ethernet data exchange, convergence, and remote optical transmission. The product has the characteristics of small size, fan-less, low power consumption, high reliability, good stability, and easy maintenance.

Industrial Ethernet switch products adopt mature technology and open network standards, adapt to low temperature and high temperature, strong anti-electromagnetic interference, anti-salt spray, anti-vibration, and anti-shake, equipped with redundant dual DC power supply (24V/48V), which can always be maintained for the needs the connected key equipment provides a redundancy mechanism. It can also work in the standard operating temperature range of -40 to 75°C. Industrial switches support DIN rail or wall-mounted installation and have IP40 protection level. They are the perfect choice for harsh environments, such as industrial networks, intelligent transportation systems (ITS), and are also suitable for many military and public utility market applications, where environmental conditions exceed commercial products specification.

Features

- Support 10/100M electrical port adaptive, full/half duplex auto-negotiation mode
- Support 100M SC/FC/ST/LC interface fiber port, support single/dual fiber transmission - Optional
- Support IEEE802.3az energy saving technology
- Support IPv6 protocol
- Power input polarity protection design, no need to worry about wrong operation
- Metal shell, fan-less design
- Installation method: DIN rail installation/wall mounting
- 8KV surge protection, safer outdoor use

Parameter

Ethernet standard	IEEE802.3 IEEE802.3u	SFP interface	Optical module optional
	IEEE802.3z IEEE802.3ab IEEE802.3x IEEE802.3az IEEE802.3ah IEEE802.1X IEEE802.1Q	RJ45 electrical port transmission distance	100m (Use standard CAT5/CAT5e cables)
Cache	5 Ports: 512Kbits/ 8 Ports: 1M	Power	
		Power supply current	0.2/0.1A
Maximum frame	2K Bytes	Operating voltage	DC 9-56V, AC 15-40V
MAC address	4K	Overvoltage protection	supported
Forwarding mode	Store-and-forward & pass- through (full/half duplex mode)	Power reverse	supported
		Power consumption	Full load <15W
Exchange performance	Delay: < 7μs Backplane bandwidth: 5 Ports:1.25Gbps 8 Ports:2Gbps	POE - Optional	
		POE standard	IEEE 802.3af/at, PSE
		POE power	Single port maximum 30W
		POE line order	1/2(+), 3/6(-)End jumper
Transmission distance		Physical characteristics	

OPTICOMBINE

Material	Metal material	Warranty	5-year warranty and lifetime maintenance
Cooling method	Natural cooling, fan-less design with finned case	Certification standards	
Installation size	5 ports 120mm x 90mm x 35mm (L x W x H)	EMI	FCC Part 15 B Class A, EN 55022 Class A
	8 ports 138mm x 106mm x 41mm (L x W x H)	EMS	EN61000-4-2(ESD), EN61000-4-3(RS), EN61000-4-4(EFT), EN61000-4-5(Surge), EN61000-4-6(CS), EN61000-4-8, EN61000-4-11
Installation method	DIN rail/wall mounting		
Weight	300g		
Environmental requirements			
Operating temperature	-40°C~75°C	Impact	IEC60068-2-27
Relative humidity	5%~90% (No condensation)	Drop	IEC60068-2-32
storage temperature	-40°C~85°C	Shock	IEC60068-2-6
Guarantee		Security Level	EN60950-1
Mean time between	500,000 Hrs.		

Products Display. Note: Different types vary.

OC-7N1000 series

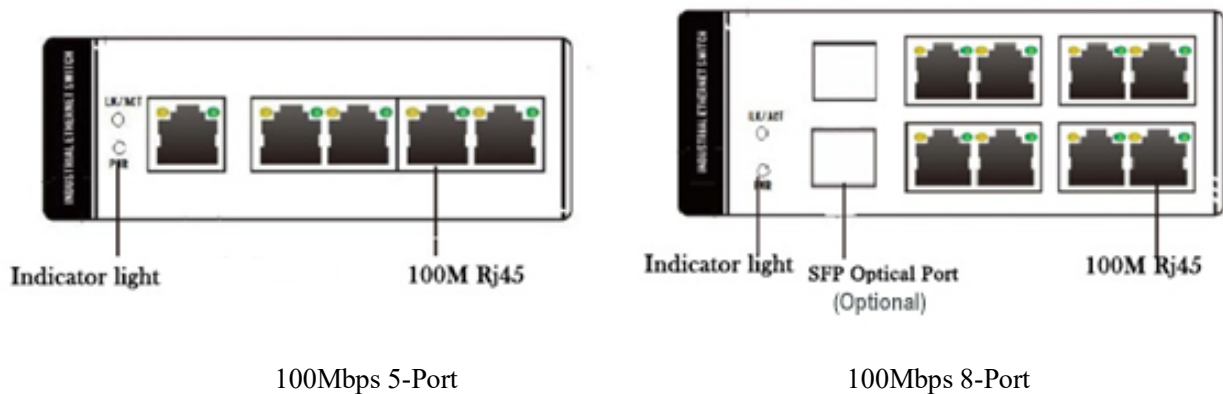

Indicator light definition

Indicator Status Description	Indicator Status Description	Indicator Status Description
Power indicator: PWR	Always on	Normal
	Always off	No power
Optical port indicator: LK/ACT (Optional)	Always on	Optical connection is normal
	Flashing	Optical port has data transmission
	Always off	Optical port is not connected
Electric port indicator	Always on	The electrical connection is normal
	Flashing	Data transmission via electrical port
	Always off	The electrical port is not connected

OPTICOMBINE

Box contents

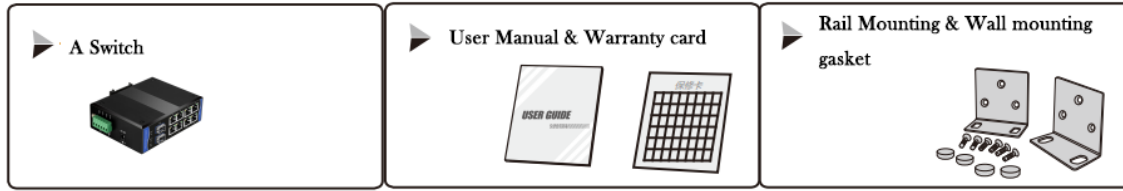

*Note: The SFP model does not contain optical modules by default. If you find that there is a shortage or damage of accessories, please contact us immediately. Please enter your order number and date onto the warranty card for future reference if needed. The Switch carries a 5-year warranty.

Applications. Note: Fibre Optic and POE are optional features.

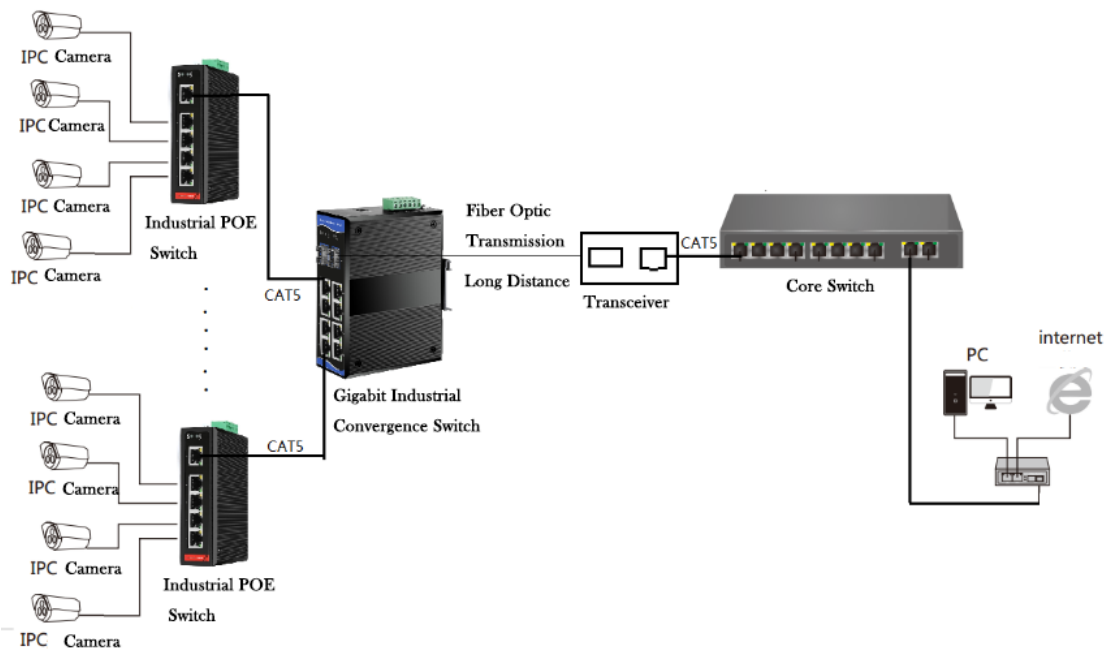

Product Size: 5 Ports for 10/100 Base,

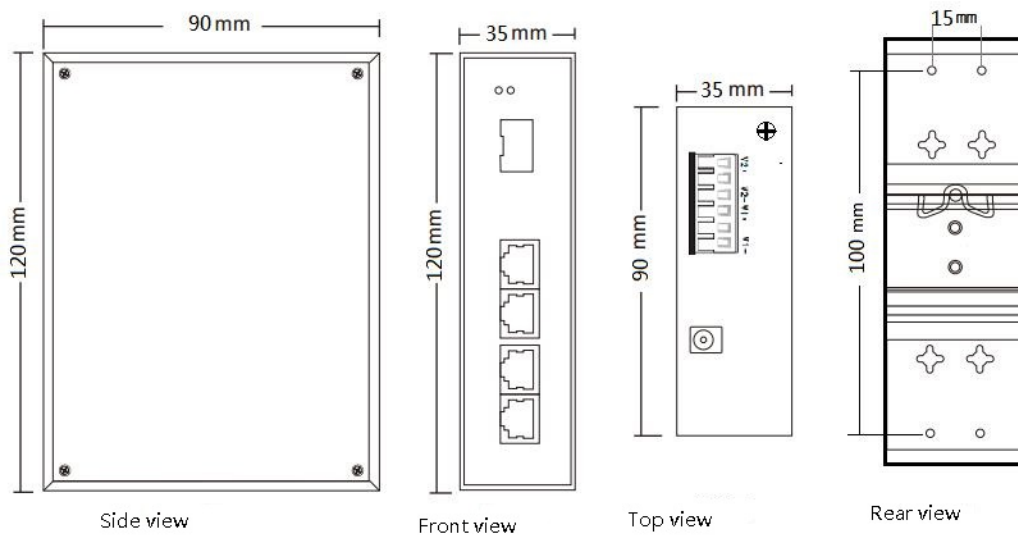

OPTICOMBINE

Product Size: 8 Ports for 10/100 Base

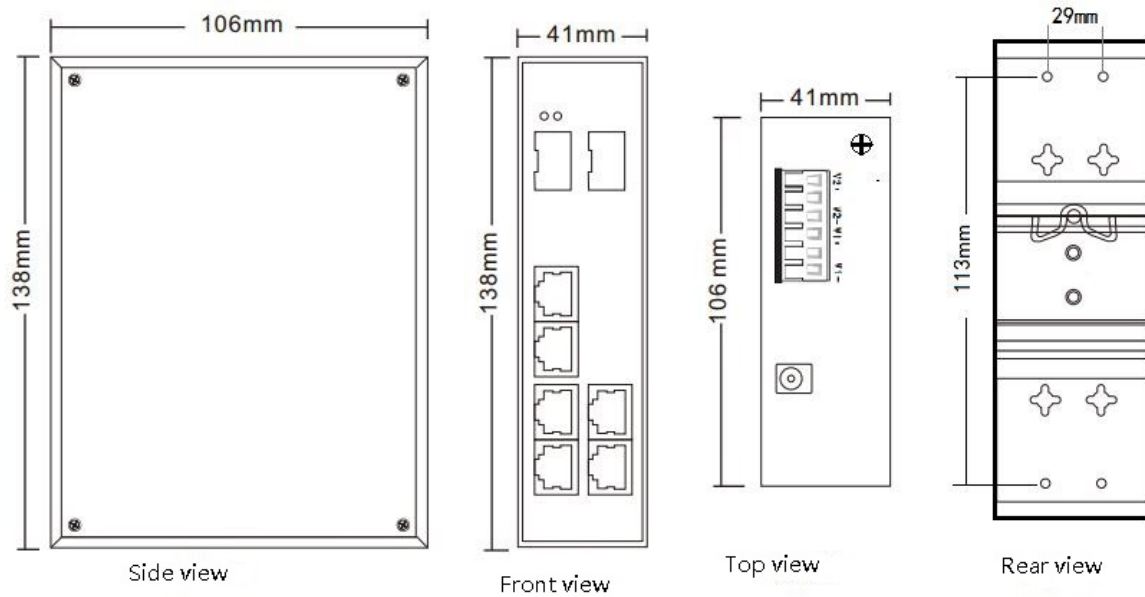

Industrial switch product installation

DIN rail installation

When unpacking, the aluminum guide rail accessory metal plate has been fixed on the back of the switch. If you need to re-install it, make sure that the metal spring is at the top, as shown in the figure below.

Step1: Insert the top of the guide rail into the groove just below the metal spring.

Step2: The rail accessories will be embedded in the rail, as shown in the following figure.

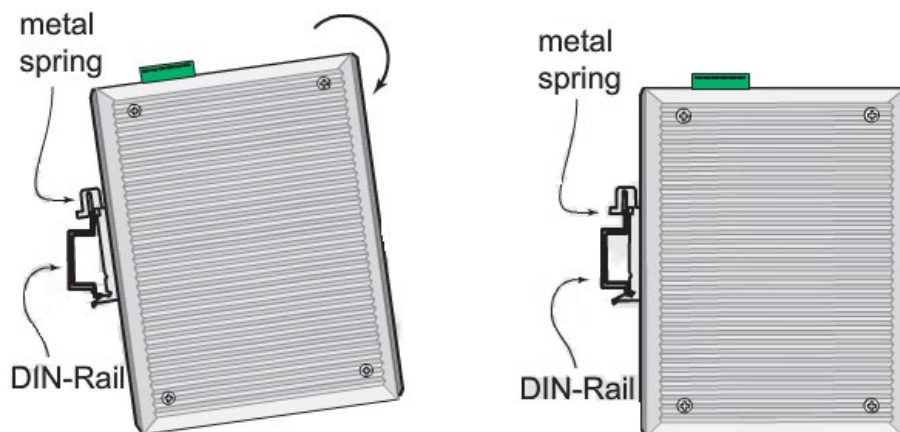

OPTICOMBINE

Wall mount

Step1: When unpacking, the aluminum guide rail accessory metal plate has been fixed on the reverse side of the switch. Remove the wall-mounted metal plate from the switch and re-install it, as shown in the figure below.

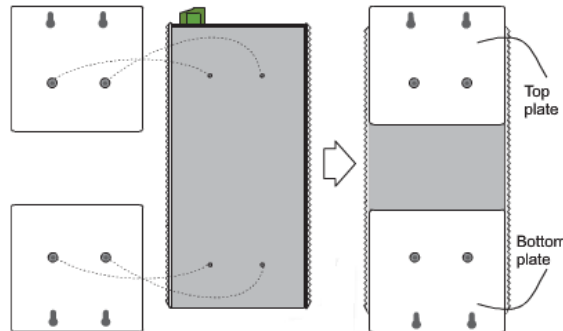

Step2: To install the switch on the wall, 4 screws are required for wall mounting.

Attention: Before screwing the screws into the wall, make sure the screw size can match the wall-mounted metal panel.

Connect the redundant power cord

Industrial switches have two redundant power inputs—PRW1 and PWR2. The connector of the Phoenix terminal wiring block is located on the top panel of the switch. The front view of the wiring board is shown below.

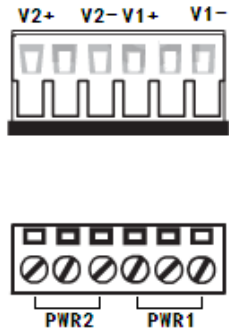
	<p>Step1: Plug the positive/negative DC wires into the V+/V- terminals respectively. AC supply polarity independent</p> <p>Step2: To prevent the cable from loosening, use a flat screwdriver to fix the wire clamp on the terminal block connector.</p> <p>Step3: Insert the Phoenix terminal wiring block into the socket on the top panel of the switch.</p>
---	---

Attention: To avoid equipment damage or personal injury caused by improper use, please observe the following precautions:

- During the installation process, keep the power off, wear an anti-static wrist **band**, and ensure that the anti-static wrist **band** is in good contact with the skin to avoid potential safety hazards;
- The switch can work normally under the correct power supply. Please confirm that the power supply voltage matches the voltage marked on the switch;
- Before powering on the switch, please confirm that it will not cause overload of the power circuit, so as not to affect the normal operation of the switch or even cause unnecessary damage;
- In order to avoid the risk of electric shock, do not open the shell when the switch is working, even when it is not live, do not open it by yourself;
- Before cleaning the switch, the power plug of the switch should be unplugged, do not wipe with wet fabric, do not clean with liquid;
- The equipment installed in the rack is generally from bottom to top to avoid overloading installation;
- Avoid placing other heavy objects on the surface of the switch to avoid accidents.