



Electromagnetic Relay Product Catalogue

Industrial Relays | Interface Relays | Timers | Sockets and Accessories



- 2 pole 3 pole contact load 16A
- With non-polarity LED integrated in relay
- With lockable test button and inspection window
- Identification of coils through test button color (AC red/DC blue)
- Conformity with RoHs Directive

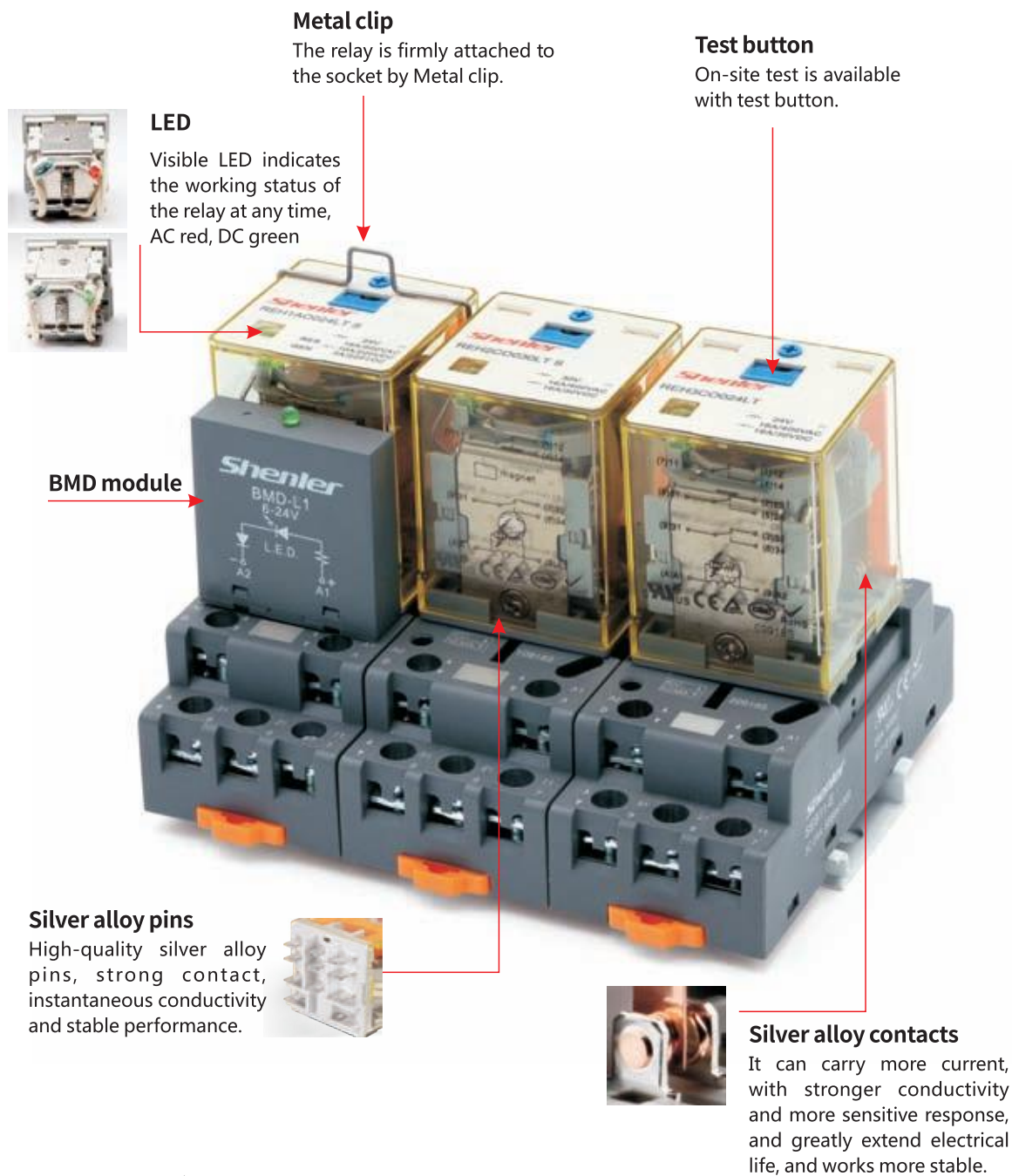

LED
Visible LED indicates the working status of the relay at any time, AC red, DC green

Metal clip
The relay is firmly attached to the socket by Metal clip.

Test button
On-site test is available with test button.

BMD module

Silver alloy pins
High-quality silver alloy pins, strong contact, instantaneous conductivity and stable performance.

Silver alloy contacts
It can carry more current, with stronger conductivity and more sensitive response, and greatly extend electrical life, and works more stable.



Relay

+



Socket

=



Relay module

REH □ □ □ □

Other options

- LT: LED + test button
- LTD: LED + test button + diode (A1-, A2+)
- LTD1: LED + Test button + diode (A1+, A2-)

Coil voltage code

Code	006	012	024	048	110	220	
Voltage (V DC)	6	12	24	48	110	220	
Code	506	524	548	615	730	880	900
Voltage (V AC)	6	24	48	115	230	380	400

Terminal arrangement

O: plug in

Contact form

- 2C: 2CO
- 3C: 3CO

Series name

Characteristics		
Configuration		2C,3C
Load	Resistance	16A/300VAC 30VDC
	Motor load	1/2HP, 120VAC; 1HP, 240VAC
Contact	Max. switching capacity (resistive)	4800VA, 480W
	Initial contact resistance	≤50mΩ
	Material	Ag alloy
	Electric durability(110%rated voltage, 55°C)	≥60 x 10 ⁴ Cycles (600 Ops/h)
	Electric durability (Normal temperature)	≥5000 x 10 ⁴ Cycles (18000 Ops/h)
	Mechanical durability	≥2000 x 10 ⁴ Cycles (18000 Ops/h)
	Pick-up voltage (23°C) (Rated voltage)	DC:≤75%, AC:≤80% 50/60Hz
Drop-out voltage (23°C) (Rated voltage)	DC:≥10%, AC:≥30% 50/60Hz	
Maximum voltage (23°C) (Rated voltage)		110%
Insulation resistance		≥1000MΩ (500VDC)
Coil operating power	DC(W)	approx. 1.5
	AC(VA)	approx. 2.5
Operate time&Release time (at nominal voltage)		≤20ms
Initial breakdown voltage	Between open contacts	1500VAC/1min (leakage current 1mA)
	Between poles	4000VAC/1min (leakage current 1mA)
	Between contacts and coil	4000VAC/1min (leakage current 1mA)
Insulation characteristics	Rated voltage	300VAC
	Pollution level	3
IEC 60664 UL840	Overvoltage level	III
Impulse withstand voltage (waveform: 1.2/50us)		6000V
Protection level		IP50
Storage temperature/ humidity		-55~+85°C/ ≤85%RH (18 months)
Working temperature/ humidity		-55~+70°C/ 5%~85%RH (No condensation) ★
Air pressure		86~106KPa
Shock resistance		10G (half-sine shock pulse: 11ms)
Vibration resistance		10~55Hz double-amplitude:1.0mm
Mounting		plug in
Unit weight		approx. 90g

★ If the storage exceeds 18 months (calculated from the factory date), it is recommended to re-test the parameters before using.

Coil Specifications (23°C)

Nominal voltage V.DC	6	12	24	48	110	220	
Coil resistance Ω	24	96	385	1540	8070	32270	
Nominal voltage V.AC	6	24	48	115	230	380	400
Coil resistance Ω	8	100	350	2200	8000	26000	27000

Coil resistance: under coil voltage 110V are measured with tolerance of ±10%Ω, above 110V with tolerance of ±15%Ω.

Contact Specification

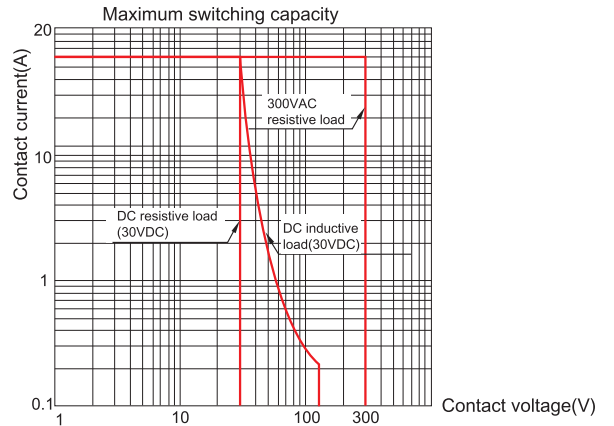
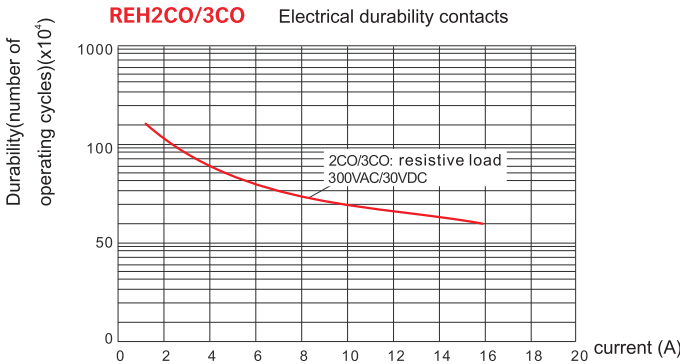

Dimensions (mm)

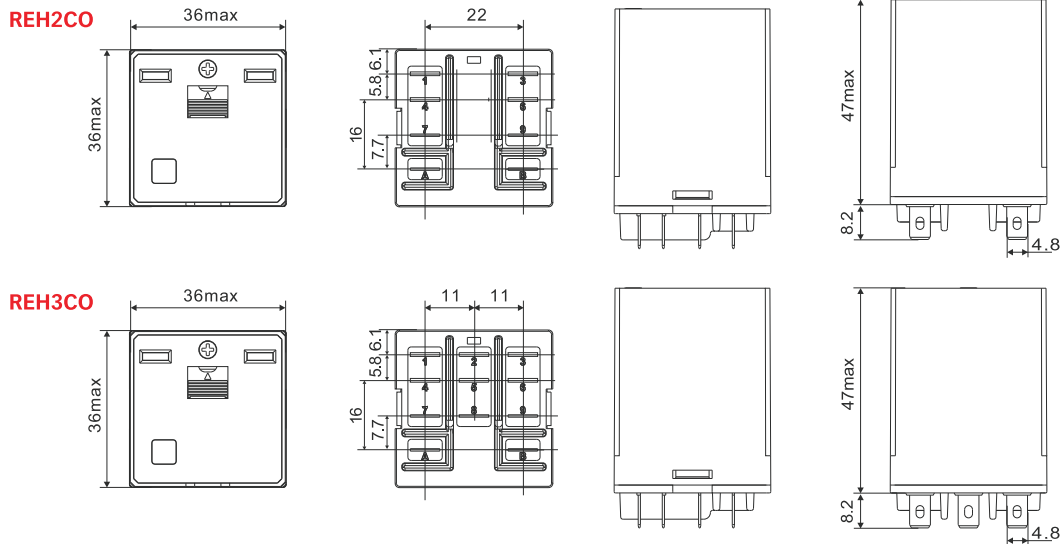

Wiring Diagrams

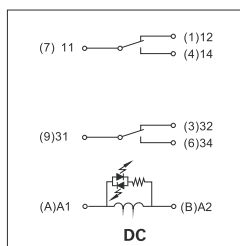

REH2CO

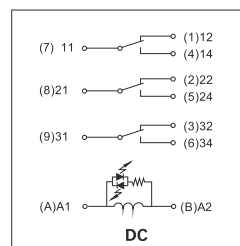
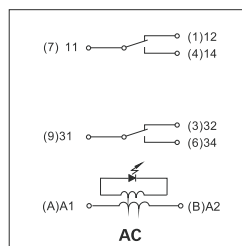

REH3CO

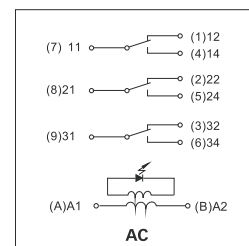



Series Name

+



Socket

=



Relay module

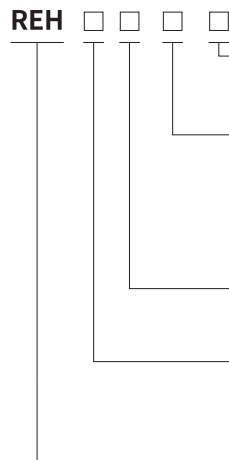

Other options

LTS: LED +test button + magnet

Coil voltage code

Code	012	024	048	110	220	
Voltage (V DC)	12	24	48	110	220	
Code	524	548	615	730	880	900
Voltage (V AC)	24	48	115	230	380	400

Terminal arrangement

O: plug in

Contact form

Code	1A	1B	2A	2B	2FO	3A
Contact form	1NO	1NC	2NO	2NC	1NO&1NC	3NO

Series name

- ◆ Good performance in DC motor load
- ◆ With non-polarity LED and lockable test button.
- ◆ High capacity load (16A@400VAC) for well replacement of contactor
- ◆ With blow-out magnet
- ◆ Identification of coil through test button color (AC red /DC blue)

Characteristics

Configuration	1A, 1B	2A, 2B, 2FO	3A		
Load	Resistance	16A/500VAC	16A/250VAC	16A/300VAC	
	Resistance	10A/220VDC 16A/30VDC			
	inductive	10A/250VAC(cosØ0.4); 3A/220VDC(L/R=7ms)			
Contact	Switching capacity	Resistance	8000VA	4000VA	4800VA
		Resistance	2200W		
		inductive	2500VA(cosØ0.4);660W(L/R=7ms)		
Initial contact resistance	≤50mΩ				
Material	Ag alloy				
Electric durability(110%rated voltage, 55°C)	≥60 x 10 ⁴ Cycles (600 Ops/h)		≥20 x 10 ⁴ Cycles (600 Ops/h)		
Mechanical durability	≥5000 x 10 ⁴ Cycles (18000 Ops/h)				
Pick-up voltage (23°C) (Rated voltage)	DC:≤75% , AC:≤80% 50/60Hz				
Drop-out voltage (23°C) (Rated voltage)	DC:≥10% , AC:≥30% 50/60Hz				
Maximum voltage (23°C) (Rated voltage)	110%				
Insulation resistance	≥1000MΩ (500VDC)				
Coil operating power	DC (W)	approx. 1.5			
	AC (VA)	approx. 2.5			
Operate time&Release time (at nominal voltage)	≤20ms				
Initial breakdown voltage	Between open contacts	1500VAC/1min (leakage current 1mA)			
	Between poles	4000VAC/1min (leakage current 1mA)			
	Between contacts and coil	4000VAC/1min (leakage current 1mA)			
Insulation characteristics	Rated voltage	400VAC	250VAC	250VAC	
	Pollution level	2	3	3	
IEC 60664 UL840	Overvoltage level	II	III	III	
Protection level	IP50				
Storage temperature/ humidity	-20~+85°C/ ≤85%RH (18 months) ★				
Working temperature/ humidity	-40~+55°C/ 5%~85%RH (No condensation)				
Air pressure	86~106KPa				
Shock resistance	10G (half-sine shock pulse: 11ms)				
Vibration resistance	10~55Hz double-amplitude:1.0mm				
Mounting	plug in				
Unit weight	approx. 90g				

★ If the storage exceeds 18 months (calculated from the factory date), it is recommended to re-test the parameters before using.

Coil Specifications (23°C)

Nominal voltage V.DC	12	24	48	110	220	
Coil resistance Ω	96	385	1540	8070	32270	
Nominal voltage V.AC	24	48	115	230	380	400
Coil resistance Ω	100	350	2200	8000	26000	27000

Coil resistance: under coil voltage 110V are measured with tolerance of ±10%Ω, above 110V with tolerance of ±15%Ω.

Contact Specification

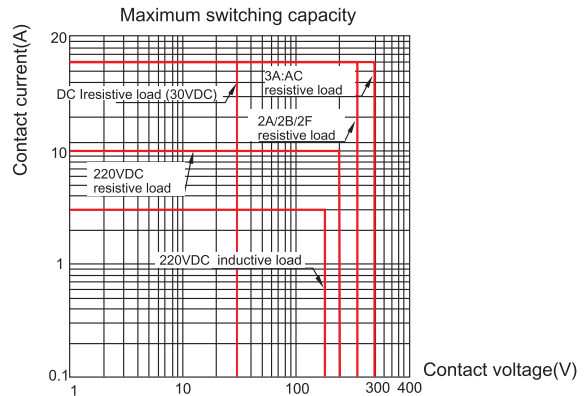
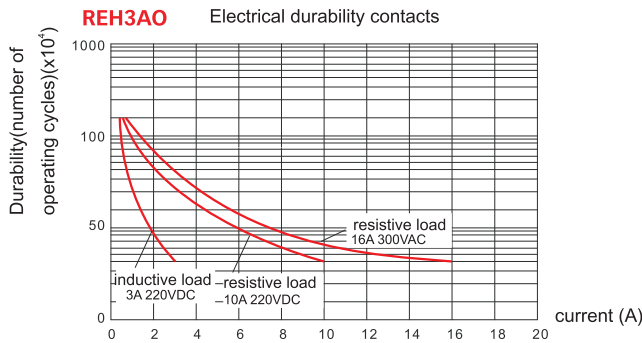
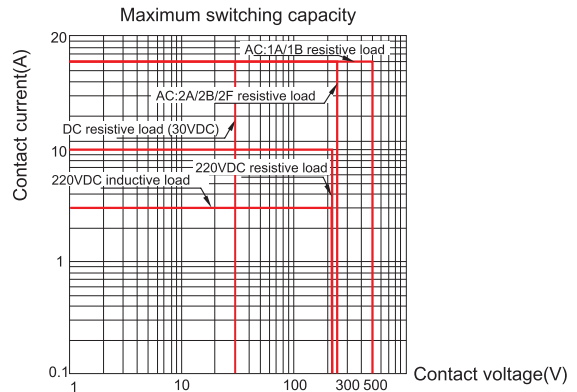
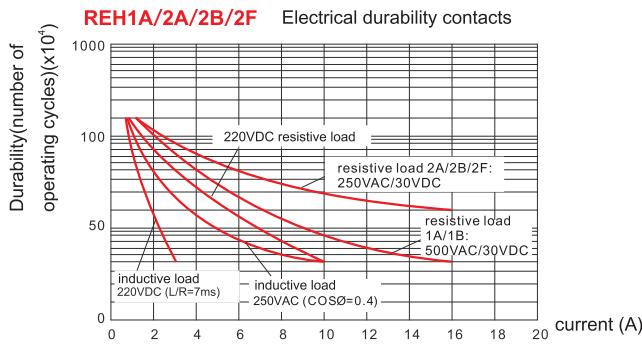

Dimensions (mm) & Wiring Diagrams

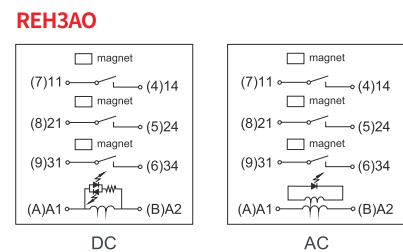
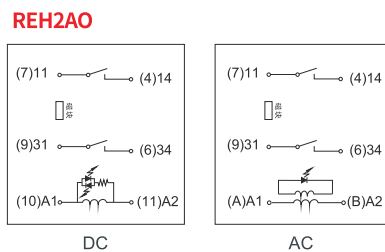
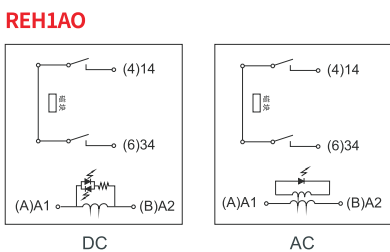
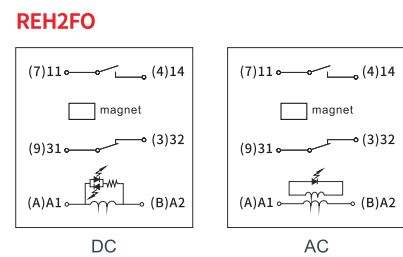
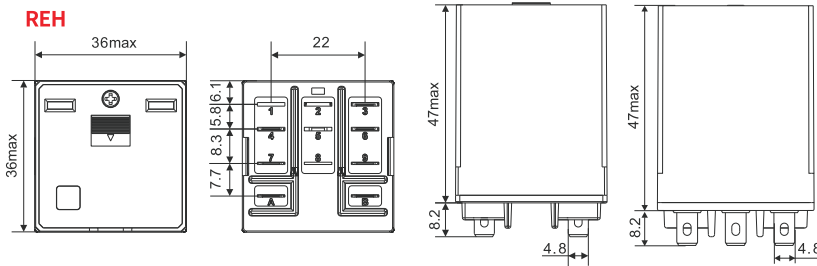

Characteristics





SEB11-E



Type			SEB11-E
Nominal load	Current	A	25
	Voltage	V	500
Dielectric strength	Between coil and contact	V/min	4000
	Between contacts	V/min	2500
Max. tightening torque	Nm	1.2	
Wire size	AWG/mm ²	20-12/0.5-3.3	
Ambient temperature	°C	-40~+75	
Unit weight	g	64	

Relay, accessories Selection Table

Socket	Metal clip	Module
SEB11-E	 SE52M	 BMD

Dimensions (mm)

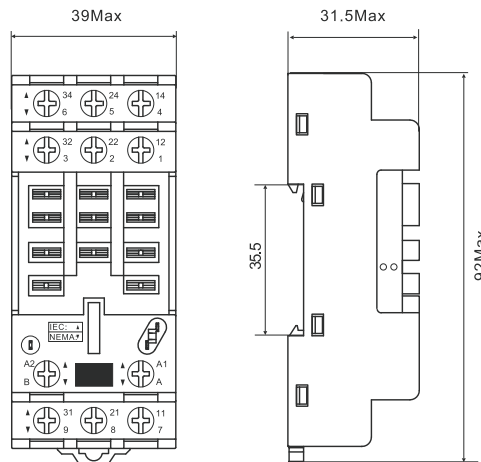

Connection Diagrams

- Ⓐ Ⓑ : A1 A2
- ① ② ③ : NC
- ④ ⑤ ⑥ : NO
- ⑦ ⑧ ⑨ : COM

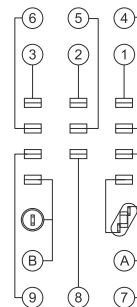

Characteristics

SEB11-P



Type			SEB11-P
Nominal load	Current	A	15
	Voltage	V	300
Dielectric strength		V/min	25000
Ambient temperature		°C	-40~+75
Unit weight		g	8.4

Relay,accessories Selection Table

Socket	Metal clip
SEB11-P	 SE48M

Dimensions (mm)

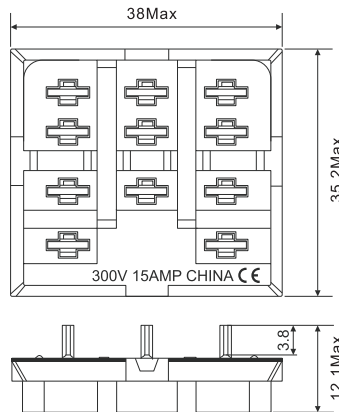

Connection Diagrams

- Ⓐ Ⓑ : A1 A2
- ① ② ③ : NC
- ④ ⑤ ⑥ : NO
- ⑦ ⑧ ⑨ : COM

