



LX3V-4AD

User manual



Website: <http://www.we-con.com.cn/en>

Technical Support: support@we-con.com.cn

Skype: fcwkkj

Phone: 86-591-87868869

QQ Group: 465230233

Technical forum: <http://wecon.freeforums.net/>



1. Introduction

- The LX3V-4AD special module has four input channels. The input channels receive analog signals and convert them into a digital value. This is called an A/D conversion; the maximum resolution is 16 bits.
- The selection of voltage or current based input/output is by user wiring. Analog ranges of -10 to 10V DC (resolution: 5mV), and/or 4 to 20mA, -20 to 20mA (resolution: 20 μ A) may be selected.
- Data transfer between the LX3V-4AD and the LX3V main unit is by buffer memory exchange. There are 32 buffer memories (each of 16 bits) in the LX3V-4AD.
- LX3V-4AD consumes 5V voltage from LX3V main unit or active extension unit, 90mA current of power supply.

2. Dimensions

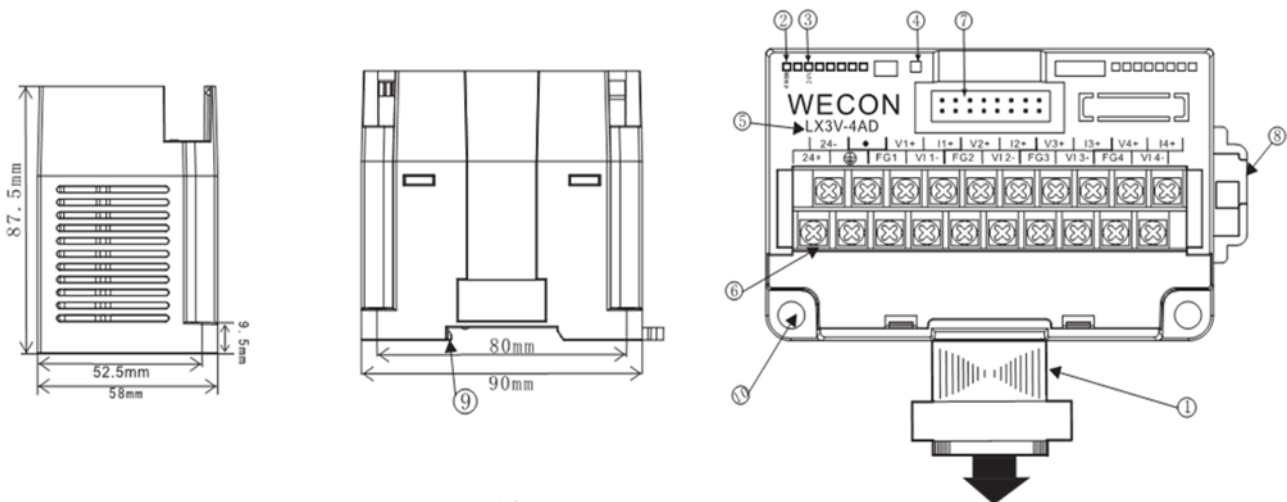

- ① Extension cable and connector
- ② COM LED: Light when communicating
- ③ Power LED: Light when connect to 24V
- ④ State LED: Light when normal condition
- ⑤ Module name

- ⑥ Analog signal output terminal
- ⑦ Extension module interface
- ⑧ DIN rail mounting slot
- ⑨ DIN rail hook

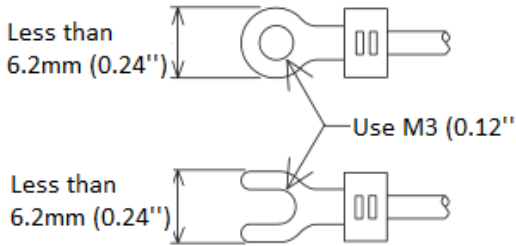

- Please use crimp terminals as indicated on the graph.
- The tightening torque should be applied 5 to 8 Kg.cm.

3. Terminal layouts

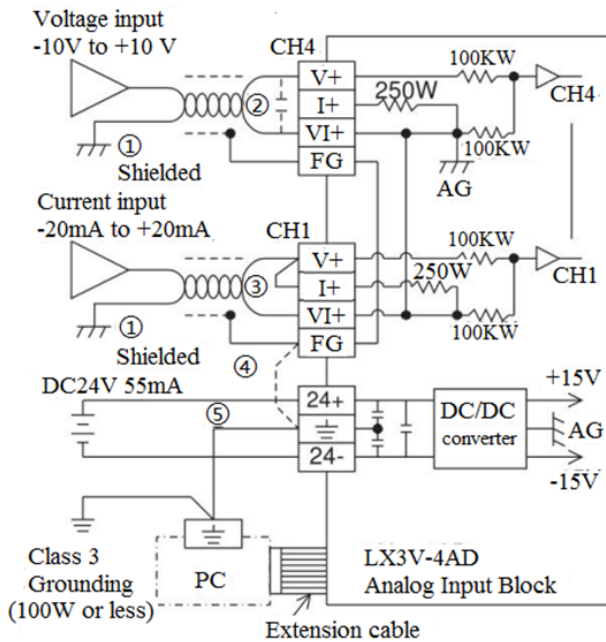

- 1) The analog input is received through a twisted pair shielded cable. This cable should be wired separately from power lines or any other lines which may induce electrical noise.
- 2) If a voltage ripple occurs during input, or there is electrically induced noise on the external wiring, connect a smoothing capacitor of 0.1 to 0.47μF, 25V.
- 3) If you are using current input, connect the V+ and I+ terminals to each other.
- 4) If there is excessive electrical noise, connect the FG frame ground terminal with the grounded terminal on the LX3V-4AD.
- 5) Connect the ground terminal on the LX3V-4AD unit with the grounded terminal on the main unit. Use class 3 grounding on the main unit, if available.

4. Installation

4.1 Environment specification

Item	Specification
Environmental specifications (excluding	Same as those for the LX3V main unit

following)	
Dielectric withstand voltage	500VAC, 1min (between all terminals and ground)

4.2 Power supply specification

Item	Specification
Analog circuits	24V DC \pm 10%, 55mA (external power supply from main unit)
Digital circuits	5V DC, 90mA (internal power supply from main unit)

4.3 Performance specification

1) Analog Inputs

	Voltage Input	Current input
Items	Either voltage or current input can be selected with your choice of input terminal. Up to four input points can be used at one time.	
Analog input range	DC -10V to +10V (input resistance: 200k Ω). Warning: this unit may be damaged by input voltage in excess of \pm 15V	DC -20mA to +20mA (input resistance: 250 Ω). Warning: this unit may be damaged by input currents in excess of \pm 32mA.
Digital output	12-bit conversion stored in 16-bit 2's complement form Maximum value:+2047 Minimum value:-2048	
Resolution	5mV (10V default range 1/2000)	20 μ A (20mA default range 1/1000)
Over all accuracy	\pm 1% (for the range of -10V to +10V)	\pm 1% (for the range of -20mA to +20mA)
Conversion speed	15ms/channel (Normal speed), 6ms/channel (High speed)	

2) Analog Inputs continued...

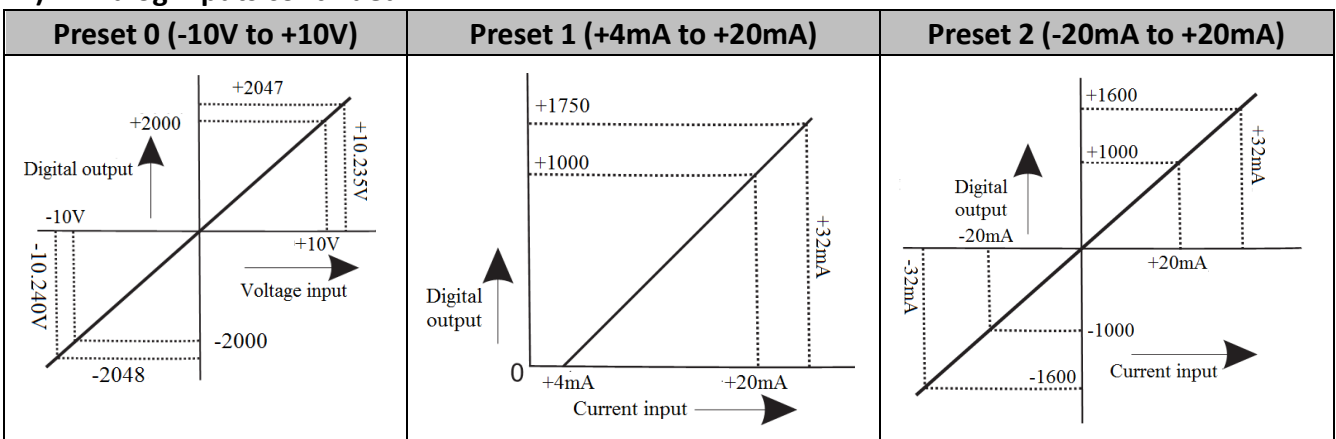

Note:

Preset ranges are selected by an appropriate setting in buffer memory of the analog block. Current/Voltage input selection must match the correct input terminal connections.

3) Miscellaneous

Item	Description
Isolation	Photo-couple isolation between analog and digital circuits. DC/DC converter isolation of power from LX3VCPU. No isolation between analog channels.

4.4 Allocation of buffer memories (BFM)

BFM	Description									
*#0	Channel initialization, default=H0000									
*#1	Channel 1	Contains the number of samples (1 to 4096) to be used for an averaged result. The default setting is 8-normal speed. High speed operation can be selected with a value of 1.								
*#2	Channel 2									
*#3	Channel 3									
*#4	Channel 4									
#5	Channel 1	These buffer memories contain the averaged input values for the number of samples entered for the channel in buffer memories #1 to #4 respectively.								
#6	Channel 2									
#7	Channel 3									
#8	Channel 4									
#9	Channel 1	These buffer memories contain the present value currently being read by each input channel.								
#10	Channel 2									
#11	Channel 3									
#12	Channel 4									
#13-#14	Reserved									
#15	Selection of A/D conversion speed please refer to note 2	When set to 0, a normal speed is selected of 15m/s.ch (default)								
		When set to 1, a high speed is selected of 6m/s.ch								
#16-#19	Reserved									
*#20	Reset to Defaults and Preset. Default = 0									
*#21	Offset, Gain Adjust Prohibit. Default = (0, 1) Permit									
*#22	Offset, Gain Adjust	b7	b6	b5	b4	b3	b2	b1	b0	
		G4	O4	G3	O3	G2	O2	G1	O1	

*#23	Offset Value Default = 0
*#24	Gain Value Default = 5,000
#25-#28	Reserved
#29	Error status
#30	Identification code K2010 (12-bit resolution) Identification code K2011 (16-bit resolution)
#31	Hardware version

- In buffer memory locations (BFM's) marked with an "*" data can be written from the PC using the TO command.
- For buffer memories (BFM's) without "*" mark, data can be read to the PC using the FROM command.
- Before reading from the analog special function block, ensure these settings have been sent to the analog special function block. Otherwise, the previous values held in the analog block will be used.
- Offset (intercept): The analog input value when the digital output becomes 0.
- Gain (slope): The analog input value when the digital output becomes +1000.

Note

1) Channel Selection

Channel initialization is made by a 4 character HEX number H0000 in buffer memory BFM #0. The least significant character controls channel 1 and the 4 character controls channel4.

BFM#0	Analog input	Digital output	Resolution	Offset/Gain	Constant
0	-10V~10V	-2000~2000	5 mV	0/5000	1000
1	4mA~20mA	0~1000	16μA	4000/20000	1000
2	-20mA~20mA	-1000~1000	20μA	0/20000	1000
3	Disabled	/	/	/	/
4	-10V~10V	-10000~10000	1mV	0/5000	10000
5	4 mA ~20mA	0~10000	1.6μA	4000/20000	10000
6	-20mA~20mA	-10000~10000	2.0μA	0/20000	10000

Example: H3310

CH1: Preset range (-10V to +10V).

CH2: Preset range (+4mA to +20mA).

CH3, CH4: Channel OFF.

2) Analog to Digital Conversion Speed Change

By writing 0 or 1 into BFM #15 of the LX3V-4AD, the speed at which A/D conversion is performed can be changed.

However the following points should be noted: To maintain a high speed conversion rate, use the FROM/TO commands as seldom as possible.

NOTES:

- When a conversion speed change is made, BFM #1-#4 are set to their default values immediately after the change. This is regardless of the values they held originally. Bear this in mind if a speed change will be made as part of the normal program execution.

3) Adjusting Gain and Offset values

Formula for Gain/Offset: Digital output= (Analog input-Offset)*Constant/ (Gain-Offset)

- When buffer memory BFM #20 is activated by setting it to K1, all settings within the analog special function block are reset to their default settings. This is a very quick method to erase any undesired gain and offset adjustments.
- If (b1, b0) of BFM #21 is set to (1, 0), gain and offset adjustments are prohibited to prevent inadvertent changes by the operator. In order to adjust the gain and offset values, bits (b1, b0) must be set to (0, 1). The default is (0, 1).
- Gain and offset values of BFM #23 and #24 are sent to non-volatile memory gain and offset registers of the specified input channels. Input channels to be adjusted are specified by the appropriate G-O (gain-offset) bits of BFM #22.

Example:

If bits G1 and O1 are set to 1, input channel 1 will be adjusted when BFM #22 is written to by a TO instruction.

- Channels can be adjusted individually or together with the same gain and offset values.
- Gain and offset values in BFM #23 #24 are in units of mV or μ A. Due to the resolution of the unit the actual response will be in steps of 5mV or 20 μ A.

4) Status Information BFM #29

Bit devices of BFM #29	ON	OFF
b0: Error	When any of b1 to b4 is ON. If any of b2 to b4 is ON, A/D conversion of all the channels is stopped	No error
b1: Offset/gain error	Offset/Gain data in EEPROM is corrupted or adjustment error.	Offset/Gain data normal

b2: Power source abnormality	24V DC power supply failure	Power supply normal
b3: Hardware error	A/D converter or other hardware failure	Hardware normal
b10: Digital range error	Digital output value is less than -2048 or more than +2047	Averaging is normal. (between 1 and 4096)
b11: Averaging error	Number of averaging samples is 4097 or more or 0 or less (default of 8 will be used)	Averaging is normal. (between 1 and 4096)
b12: Adjust prohibit	Prohibit-(b1, b0) of BFM #21 is set to (1, 0)	Permit-(b1, b0) of BFM #21 is set to (0,1)

NOTE:

- b4 to b7, b9 and b13 to b15 are undefined.

5) Identification Code BFM #30

The identification (or ID) code number for a Special Function Block is read using the FROM command.

This number for the LX3V-4AD unit is K2011 or K2010.

The user's program in the PC can use this facility in the program to identify the special function block before commencing data transfer from and to the special function block.

NOTE:

- Values of BFM #0, #23 and #24 are copied to EEPROM memory of the LX3V-4AD. BFM #21 and BFM #22 are only copied when data is written to the gain/offset command buffer BFM #22. Also, BFM #20 causes writing to the EEPROM memory. The EEPROM has a life of about 10,000 cycles (changes), so do not use programs which frequently change these BFMs.
- Because of the time needed to write to the EEPROM memory, a delay of 300 ms is required between instructions that cause a write to the EEPROM. Therefore, a delay timer should be used before writing to the EEPROM a second time.

5. Defining gain and offset

Gain determines the angle or slope of the calibration line, identified at a digital value of 1000.

(a) Small gain: Large steps in digital readings

(b) Zero gain: Default is 5V or 20mA.

(c) Large gain: Small steps in digital readings.

Offset is the “Position” of the calibrated line, identified at a digital value of 0.

(d) Negative offset.

(e) Zero offset: Default is 0V or 4mA.

(f) Positive offset.

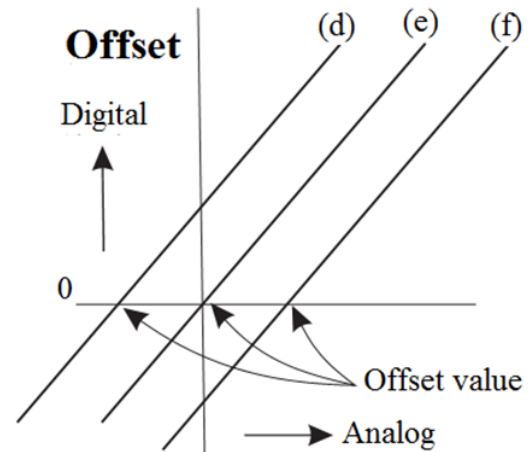
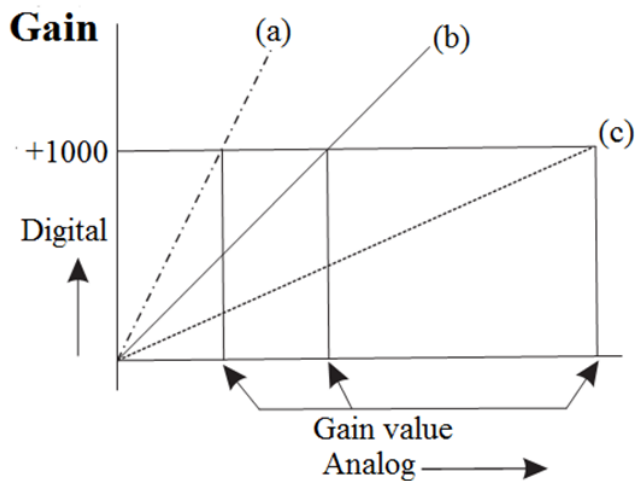

Offset and gain can be set independently or together. Reasonable offset ranges are -5 to +5V or -20mA to 20mA, and gain values 1V to 15V or 4mA to 32mA. Gain and offset can be adjusted by software in the LX3V main unit (please refer to program example 2).

- Bit device’s b1, b2 of the gain/offset BFM #21 should be set to 0, 1 to allow adjustment.
- Once adjustment is complete these bit devices should be set to 1, 0 to prohibit any further changes.
- Channel initialization (BFM #0) should be set to the nearest range, i. e. voltage/current etc.

6. Example program

6.1 basic program

In the following example channels CH1 and CH2 are used as voltage inputs. The LX3V-4AD block is connected at the position of special function block No.0. Averaging is set at 4 and data registers D0 and D1 of the PC receive the averaged digital data.

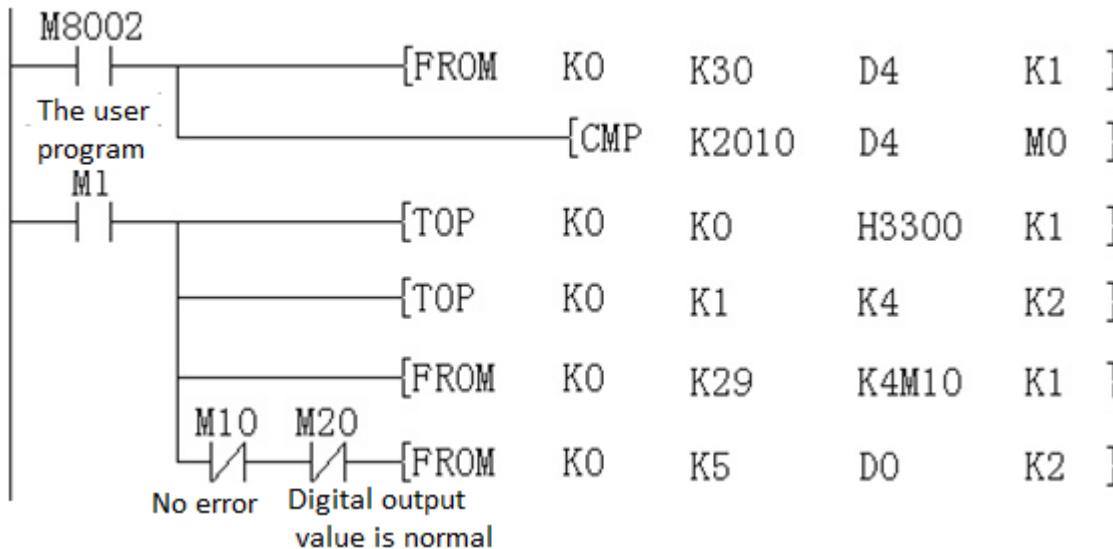

Note

- 1) The FROM code for the special function block at position "0" is read from BFM #30 of that block and stored at D4 in the main unit. CMP is compared to check the block is a LX3V-4AD, if OK M1 is turned ON.
- 2) TO code: The analog input channels (CH1, CH2) are setup by writing H3300 to BFM #0 of the LX3V-4AD
- 3) The number of averaged samples for CH1 and CH2 is set to 4 by writing 4 to BFM #1 and #2 respectively.
- 4) The operational status of the LX3V-4AD is read from BFM #29 and output as bit devices at the LX3V main unit. If there are no errors in the operation of the LX3V-4AD, then the averaged data BFM's are read.
- 5) In the case of this example BFM #5 and #6 are read into the LX3V main unit and stored at D0 and D1. These devices contain the averaged data for CH1 and CH2 respectively.

6.2 Using gain and offset in a program

The gain and offset of the LX3V-4AD can be adjusted using push-button switches on the input terminal of the PC. It can also be adjusted using software settings sent from the PC.

Only the gain and offset values in the memory of the LX3V-4AD need be adjusted. A voltmeter or an ammeter for the analog input is not needed. A program for the PC will be needed however.

The following is an example of changing the offset value on input channel CH1 to 0V and the gain value to 2.5V.

The LX3V-4AD block is in the position of block No.0 (i.e. closest to the LX3V main unit).

Example: Adjusting gain/offset via software settings

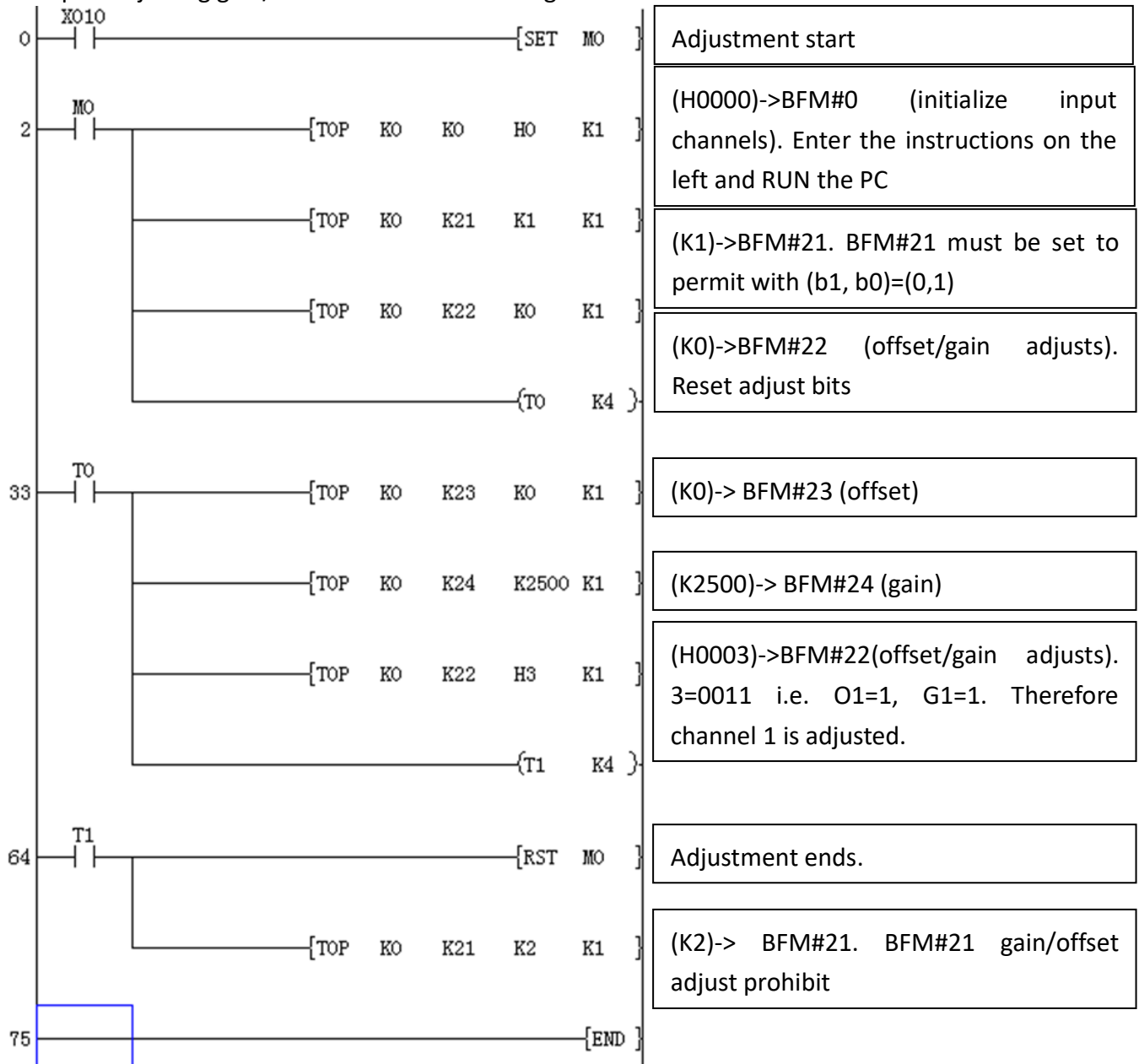

7. Diagnostics

7.1 Preliminary checks

- 1) Check whether the input wiring and/or extension cables are properly connected on LX3V-4AD analog special function block.

- 2) Check that the LX3V system configuration rules have not been broken, i.e. the number of special function blocks does not exceed 8 and the total system I/O is equal or less than 256 I/O.
- 3) Ensure that the correct operating range has been selected for the application.
- 4) Check that there is no power overload on either the 5V or 24V power sources, remember the loading on a LX3V main unit or a powered extension unit varies according to the number of extension blocks or special function blocks connected.
- 5) Put the LX3V main unit into RUN.

7.2 Error checking

- If the LX3V-4AD special function block does not seem to operate normally, check the following items.
Check the status of the POWER LED.
Lit: The extension cable is properly connected.
Otherwise: Check the connection of the extension cable.
- Check the external wiring.
- Check the status of the “24V” LED (top right corner of the LX3V-4AD).
Lit: LX3V-4AD is OK; 24V DC power source is OK.
Otherwise: Possible 24VDC power failure, if OK possible LX3V-4AD failure.
- Check the status of the “A/D” LED (top right corner of the LX3V-4AD).
Lit: A/D conversion is proceeding normally.
Otherwise: Check buffer memory #29 (error status). If any bits (b2 and b3) are ON, then this is why the A/D LED is OFF.