



Cabinet Air Conditioner Handbook

CTACG0526N

Content

1	Preface.....	4
2	Product Introduction	4
3	Transportation and Test	4
4	Working Model	5
4.1	Working Principle	5
4.2	Cooling	5
4.3	Heating(optional)	5
4.4	Air Supply Fan Control.....	6
5	Technical Parameter	7
5.1	Series Performance Parameter Chart	7
5.2	Wiring Diagram	8
5.3	Overall Dimensional Drawing	9
5.4	Opening Diagram	10
6	Installation Guide	11
6.1	Before Installation	11
6.2	Installation Instruction	12
6.3	Electrical Installation	13
7	Controller interface introductio	14
7.1	Operating Instruction	14
7.2	Display Instruction	15
7.3	Warning Code	15
7.4	User Parameter Setting	16
8	Fault Diagnosis	17
9	Repairing & Maintenance .	18

9.1	Regular Check	18
9.2	Regular Maintenance	18
10	After-sales Service and Warranty	19
10.1	Warranty Period	19
10.2	Warranty Scope	19
10.3	Disclaimer	19
11	Obsolescence and Recycle	19
12	Signal Output Description	20
12.1	Modbus	20

1. Preface

This handbook introduces everything about cabinet air conditioners in detail, please treat it seriously to have a safer and better experience.

Please keep user guide properly after reading it in case check it later. Cooltec reserves the proprietorship of this handbook, especially the right to copy, distribute and translate. The above also applies in the case of Cooltec patents and trademark rights.

Without the prior written approval of Cooltec, this user manual can not be reproduced, processed, or distributed in any conventional or electronic ways.

2. Product Introduction

Cooltec cabinet air conditioner is independently developed for the cooling of communication cabinets. It is suitable for applications where the internal heat of the cabinet is relatively large, the internal electronic equipment is sensitive to the ambient temperature, and the inside and outside need to be completely isolated.

The Cooltec air conditioner is well-equipped, qualified, and easy-installed. It can work immediately after powering on, no extra debugging is needed.

3. Transportation and Test

Please keep the air conditioner upright and put it in a horizontal place when it is unpacked. Make sure to place it upright for at least five minutes before starting to operate.

Please get the correct power supply parameters from the nameplate, and then connect the power cord to a well-grounded power supply. The minimum current of the supply line should be at least 125% of the current shown in the design data section of the corresponding air conditioner.

Please do not connect any other equipment to the circuit supplied to the cabinet air conditioner in the case of being overloaded. The evaporator fan should run immediately after the cabinet air conditioner is powered on. Please run it for about 5 to 10 minutes. During this period, the evaporator fan and compressor should be running, and no abnormal noise or vibration should be found.

It is necessary to set the temperature of the refrigeration thermostat lower than the ambient temperature for the compressor to operate.

After a few minutes, the air temperature around the condenser should be warmer than the normal room temperature.

4. Working Model

4.1 Working Principle

After the air conditioner is powered on, the low-pressure steam of the refrigerant in the refrigeration system is sucked by the compressor and compressed into high-pressure steam, and discharged to the condenser. At the same time, the air sucked by the fan outside the cabinet flows through the condenser, taking away the refrigerant and releasing it.

The heat condenses the high-pressure refrigerant vapor into a high-pressure liquid. The high-pressure liquid is sprayed after passing through the throttling device into the evaporator and evaporates at the corresponding low pressure, absorbing the surrounding heat. At the same time, the fan in the cabinet makes the air continuously exchange heat through the fins of the evaporator, and sends the cooled air to the cabinet after heat release. In this way, the air in the cabinet is continuously circulated to achieve the purpose of reducing the temperature.

4.2 Cooling

1. Cooling starts when the indoor temperature reaches the “cooling setting temperature”+ “cooling return temperature”.
2. Cooling stops when the indoor temperature reaches the “cooling setting temperature”.
3. The air conditioner parameters can be set through the display screen or background software: cooling on the temperature and cooling off the temperature.

Refrigeration parameter setting points

Parameter	Default	Setting range	Unit
Refrigeration start temperature	30	0 ~ 50	℃
Refrigeration return temperature	2	1 ~ 10	℃

4.3 Heating(optional)

1. Heating starts when the indoor temperature reaches the “heating setting temperature”+ “heating return temperature”.
2. Heating stops when the indoor temperature reaches the “heating setting temperature”;

Heating parameter setting points

Parameter	Default	Setting range	Unit
Heating start temperature	5	0 ~ 50	℃
Heating return temperature	2	1 ~ 10	℃

4. 4 Air Supply Fan Control

When the working mode of the air supply fan is set to the [Normally Open] mode, the air supply fan remains on;

When the working mode of the air supply fan is set to [follow-up] mode, the air supply fan starts when the compressor starts, without the need for

When cooling, delay the fan for 1 minute to turn off;

5 Technical Parameter

5.1 Series Function Parameter Sheet

Model	CTACG0526N	
Dimensions		
Dimensions(flange included)(mm)	mm	508*300*216
Dimensions(w/t flange included)(mm)	mm	508*300*216
Weight	Kg	18
Protection grade	IP54	
Surface treatment	OutdoorRAL7035	
Refrigeration function data		
Cooling capacity (L35/L35)	W	500
Cooling consumption power	W	280
Working temperature range	°C	20 ~ 55
Air volume	m ³ /h	180
Noise	dB (A)	60
Refrigerant	R134a	
Heating function data	Optional	
Heating function data		
Heating capacity	W	NA
Electrical data		
Power supply system	AC 230V+/-10% 50/60HZ	
Rated current	A	1.3
Maximum current	A	2.5
Locked-rotor current	A	5

5.2 Wiring Diagram

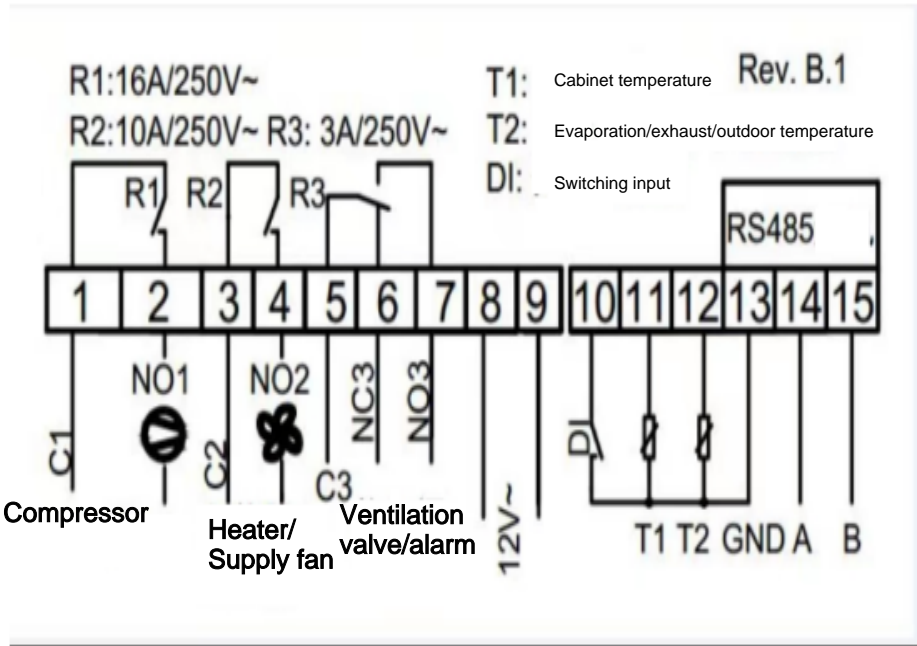

5.3 Overall Dimensional Diagram

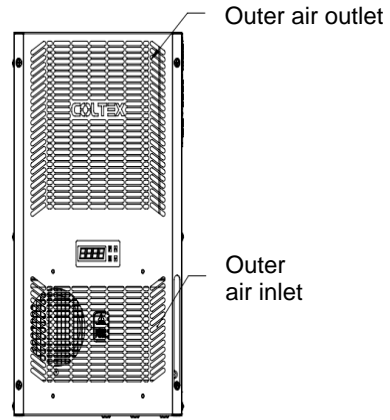
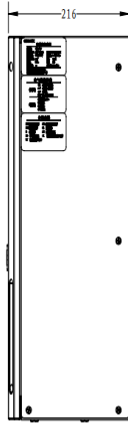
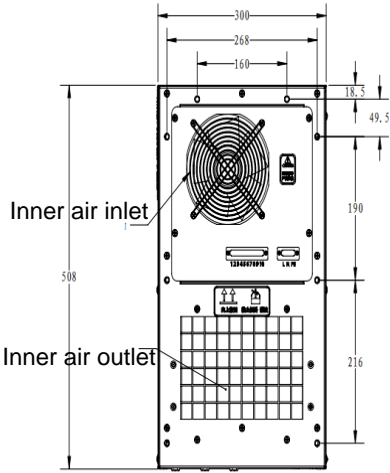
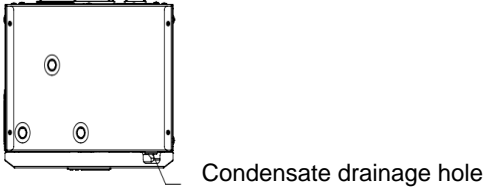

5.4 Opening Diagram

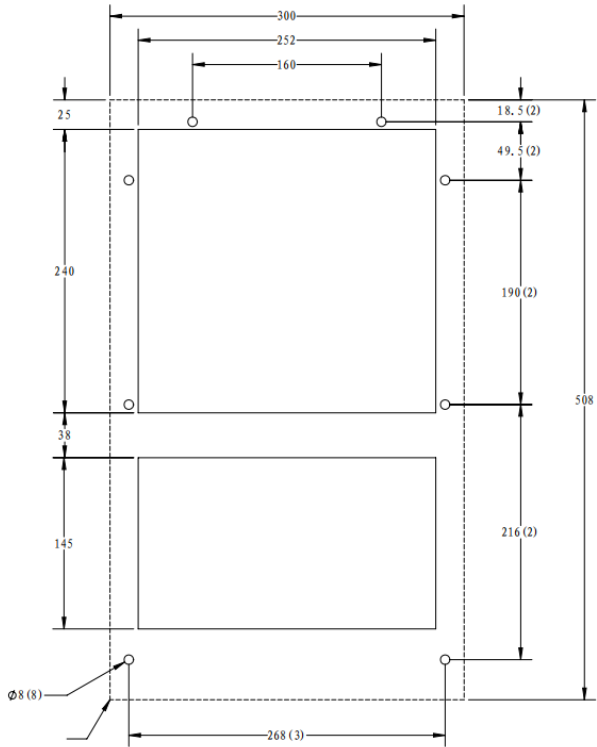

The dashed line represents the outline of the air conditioner

Wall mounted installation hole diagram

6 Installation Guide

6.1 Before Installation

To make sure the air-conditioner performs successfully, please follow the instruction:

1. To avoid overflow of condensed water, please make sure that the air conditioner keeps upright during the installation, and make the inclination angle no more than 3 degrees.
2. Please move it gently and do not bump it in case the surface is scratched.
3. Please check the air conditioner after unpacking. If there is any part being damaged or deformed, please contact local maintenance personnel.
4. Please check the accessories by list, and prepare the installation tools.
5. Please make sure there is at least a 50cm clearance between any obstruction and the condenser air inlet and outlet to avoid a return air short circuit.
6. The installation must be fulfilled by professionals according to this guide.
7. Please check the drainage to avoid drain blocking during installation.
8. Please support the external hanging cabinet during its transportation.
9. To contribute to the environmentally friendly community, please recycle the packaging.

6.2 Installation instruction

1. Check the air conditioner and make sure it can function well. See more from page 3.
2. Prepare the cabinet according to the dimension drawing from this handbook.
3. Please do not damage the gasket during installation, and do not drag the air conditioner on the cabinet. The gasket is used to seal the gap between the air conditioner and cabinet, being damaged can cause waterproof failure.
4. Please connect the power cord to a well-grounded power source according to the nameplate on the machine. Circuits should be fitted with slow-blow fuses or HACR circuit breakers.

6. 3 Electrical Installation

The electrical installation includes an AC power input port, air conditioner alarm output port & RS485 communication port, etc.



Power line connection :

Port	Definition	Description
L	Live wire	Maximum power line 2.5mm ²
N	Naught wire	
PE	Earth Wire	

Signal line connection :

Port	Definition	Description
1	NC	Fault Alarm Normally Closed
2	COM	Fault Alarm Common Terminal
3	NO	Fault Alarm Normally Open
4	DI	Passive Switch Input
5	COM	Passive Switch Input
6	GND	RS485
7	A	RS485
8	B	RS485





7.Controller Interface Introduction



7.1 Operating instruction

P	PROGRAM	Press and hold "P" on the main page to enter the system parameter setting page
S	SET	<ol style="list-style-type: none"> 1. When on the parameter setting page, briefly press this key to switch between displaying the parameter code and parameter value settings 2. Press and hold "SET" on the main page to enter the user parameter setting page
▲	UP	<ol style="list-style-type: none"> 1. In the parameter setting state, short press this key to set the parameter increase, and long press this key to set the parameter increase quickly 2. On the main page, press this button to see the evaporator temperature
▼	DOWN	<ol style="list-style-type: none"> 1. In the parameter setting state, short press this key to set the parameter increase, and long press this key to set the parameter increase quickly 2. Long press this button to forcibly start the compressor or forcibly shut it down

7.2 Display Instruction

ICON	FUNCTION	ON	OFF	GLITTERING
	COMPRESSOR	START	STOP	Ready for cooling/ compressor/ delayed protection
	AIR SUPPLY FAN	RUNNING	STOP	—
	REPARING	OUT OF ORDER	FREE OF OBSTACLE	—
	ALARM	ALARMING	NO ALARM	—
AUX	ELECTRICAL HEATING	RUNNING	—	—
HCCP	COMPULSORY COMPRESSOR	FORCED OPERATION	—	—

7.3 Warning Code

Number	Code	Definition
1	E01	Humiture sensor break(open or shorted circuits)
2	E02	Evaporator temperature sensor break (open or shorted circuits)
3	E03	System refrigerant deficiency protection
4	Hi	High temperature alarm
5	Lo	Low temperature alarm

7.4 User Parameter Setting

Use a set of passwords to enter the parameter setting state (factory default password is 1111), press the 'S' key and keep it

After 3 seconds, enter the user parameter setting state, and the digital tube will display '---0'. Press ' '

Key cycle to select the current password position, press the key to set the current password value, and after the password setting is completed

Press the 'S' key to confirm. If the password is incorrect, the 'Err' buzzer will sound three times before exiting the parameter setting

Set the state; If the password is entered correctly, the buzzer will sound once and enter the parameter setting state. At this time

The code tube displays 'U10 ', use the ' 'or' 'keys to select the parameter code, select a parameter, and then press the

The 'S' key displays the set value of the parameter, and then press the ' 'or' 'key to adjust the parameter

After setting, press the 'S' button again to return to the displayed parameter code status.

Serial No	Display Code	Name	Value Range	Unit	Default	Meaning
1	U00	Cooling Temperature Setting	0 ~ 50	℃	30	Set cooling start temperature
2	U02	Cooling Differential	1 ~ 10	℃	2	Cooling differential
3	U03	High Temperature Alarm	-5 ~ 60	℃	50	--
4	U04	Low Temperature Alarm	-5 ~ 60	℃	5	--

8. Fault Diagnosis

Fault State	Cause Analysis
Air conditioning not cool or dehumidify	Aluminum foil fin blocked / fan not working / compressor not working / refrigerant leakage
Compressor not start	Line voltage too low(It should be within $\pm 10\%$ range of the rated voltage) /Overload protection switch damage / compressor stalling
Circuit breaker burnout	Too small circuit breaker / fuse or no interval time/ line short circuit
Water ingress into the cabinet	Drainage blockage / drainage pipe knot / cabinet no seal / gasket damage
Evaporator freezing	<ol style="list-style-type: none"> 1. Internal air circulation short circuit ; 2. Cabinet air inlet or outlet poor ; 3. Internal fan failure ; 4. Refrigeration system can not be closed ; 5. Evaporator middle part temperature sensor false alarm.
High humidity in cabinet	<ol style="list-style-type: none"> 1. Excessive environmental humidity; 2. Dehumidification system failure; 3. Cabinet humidity sensor false alarm.
Heater break	Heater break
High temperature in the cabinet	<ol style="list-style-type: none"> 1. Condenser blockage or scaling; 2. Excessive ambient temperature; 3. Failure of the refrigeration system; 4. Large heat dissipation equipment within cabinet; 5. Inappropriate temperature setting; 6. In-cabinet temperature sensor false alarm
Sensor break	Sensor damage, breakdown or short circuit/sensor damage

9 Cabinet Maintenance

9.1 Regular Check

1. Please check the power cable and communication cable of the cabinet, and make sure it can work well.
2. Check the cabinet and make sure that there is no significant temperature difference between the air inlet and outlet inside and outside the cabinet when the refrigeration system is started.
3. Check the fan and compressor, make sure they can work normally there is any obvious abnormal sound or vibration when the cabinet is running.
4. Check the mechanical structure, and make sure it is damaged or deformed.
5. Check the air conditioner air inlet and outlet of the internal and external circulation and the mesh screen of the air inlet and outlet of the protective cover outside the cabinet, make sure they can work well.
6. Please ask maintenance personnel to check the cabinet every 3-6 months according to the local air condition.

9.2 Regular maintenance

Dust can cover the fins of the heat exchanger when the cabinet air conditioner works, which will cause thermal resistance and affect the performance of heat exchange. Please maintain it every 3-6 months according actual running time and local air condition. Please do not use organic solvents such as hot water or gasoline to clean when cleaning.

10 After-sales Service and Warranty

10.1 Warranty Period

In the case of correct use of the cabinet air conditioner, the warranty period agreed in the contract shall prevail.

10.2 Warranty Scope

During the warranty period of the air conditioner, if the fault is caused by the quality problem of the product itself, the manufacturer will repair it for you free of charge. Please provide the product number when implementing the warranty clause. If the fault caused by the following reasons does not belong to the scope of free repair:

1. The warranty period has expired
2. The product serial number cannot be provided
3. Cabinet air conditioner break down due to operation under abnormal conditions or environments, or due to improper installation, maintenance, or other operations
4. Faults not caused by the air conditioner itself, such as faults caused by the user's equipment, user's software, etc
5. Damage caused by the user's or other unauthorized staff's improper replacement or decomposition of the cabinet air conditioner part.
6. Damage caused by force majeure such as fire, earthquake, flood, etc.

10.3 Disclaimer

The warranty is limited to the product that has been sent, and the air conditioner manufacturer is not responsible for any damages that may arise from equipment breakdown.

11 Obsolescence and Recycle

Please obsolesce and recycle the products properly according to the local law.

12 Signal Output Description

12.1 Modbus

This controller implies RS485, and the Modbus is Modbus RTU, the parameters are as follows

Communication method: serial asynchronous half-duplex

Baud rate: 2400, 4800, 9600, 19200BPS

Data bit length: 8 bits

Parity bit: None

Start bit: 1 bit

Stop bit: 1 bit



Cooltec Cooling Technology (Qingdao) Co.,Ltd.
182 Haier Road, Laoshan District, Qingdao
City, Shandong Province, China
www.cooltechx.com